



**INFORMAZIONI GENERALI  
GENERAL INFORMATION  
ALLGEMEINE INFORMATIONEN  
INFORMATIONS GENERALES**

Paragrafo  
Chapter  
Abschnitt  
Paragraphe

Pagina  
Page  
Seite  
Page

	<b>Descrizione</b>	<b>Description</b>	<b>Beschreibung</b>	<b>Description</b>	
1	Simbologia e unità di misura	<i>Symbols and units of measure</i>	Symbole und Maßeinheiten	<i>Symboles et unités de mesure</i>	2
2	Coppia	<i>Torque</i>	Abtriebsmoment	<i>Couple</i>	4
3	Potenza	<i>Power</i>	Leistung	<i>Puissance</i>	4
4	Potenza termica	<i>Thermal capacity</i>	Termische Grenzleistung	<i>Puissance thermique</i>	5
5	Rendimento	<i>Efficiency</i>	Wirkungsgrad	<i>Rendement</i>	6
6	Rapporto di riduzione	<i>Gear ratio</i>	Getriebeübersetzung	<i>Rapport de réduction</i>	6
7	Velocità angolare	<i>Angular velocity</i>	Drehzahl	<i>Vitesse angulaire</i>	7
8	Momento d'inerzia	<i>Moment of inertia</i>	Trägheitsmoment	<i>Moment d'inertie</i>	7
9	Fattore di servizio	<i>Service factor</i>	Betriebsfaktor	<i>Facteur de service</i>	8
10	Manutenzione	<i>Maintenance</i>	Wartung	<i>Entretien</i>	9
11	Selezione	<i>Selection</i>	Antriebsauswahl	<i>Sélection</i>	10
12	Verifiche	<i>Verification</i>	Prüfungen	<i>Vérifications</i>	13
13	Installazione	<i>Installation</i>	Installation	<i>Installation</i>	15
14	Stoccaggio	<i>Storage</i>	Lagerung	<i>Stockage</i>	16
15	Condizioni di fornitura	<i>Conditions of supply</i>	Lieferbedingungen	<i>Conditions de livraison</i>	17
16	Specifiche della vernice	<i>Paint specifications</i>	Angaben zu den Antrichstoffe	<i>Spécifications de la peinture</i>	17

**RIDUTTORI COASSIALI SERIE C  
HELICAL GEAR UNITS SERIES C  
STIRNRADGETRIEBE SERIE C  
MOTOREDUCTEURS COAXIAUX SERIE C**

17	Caratteristiche costruttive	<i>Design characteristics</i>	Konstruktive Eigenschaften	<i>Caractéristiques de construction</i>	18
18	Forme costruttive	<i>Versions</i>	Bauformen	<i>Formes de construction</i>	19
19	Designazione	<i>Designation</i>	Bezeichnung	<i>Désignation</i>	20
20	Lubrificazione	<i>Lubrication</i>	Schmierung	<i>Lubrification</i>	24
21	Posizioni di montaggio e orientamento morsetti	<i>Mounting position and terminal box angular position</i>	Einbaulagen und lage des klemmenkastens	<i>Positions de montage et orientation boîte a borne</i>	25
22	Carichi radiali	<i>Overhung loads</i>	Radialkräfte	<i>Charges radiales</i>	38
23	Carichi assiali	<i>Thrust loads</i>	Axialkräfte	<i>Charges axiales</i>	41
24	Dati tecnici motoriduttori	<i>Gearmotor rating charts</i>	Getriebemotorenauswahltabellen	<i>Données techniques motoréducteurs</i>	42
25	Dati tecnici riduttori	<i>Gearbox rating charts</i>	Getriebe auswahltabellen	<i>Données techniques réducteurs</i>	74
26	Predisposizioni possibili	<i>Motor availability</i>	Anbaumöglichkeiten	<i>Prédispositions possibles</i>	96
27	Momento d'inerzia	<i>Moment of inertia</i>	Trägheitsmoment	<i>Moment d'inertie</i>	98
28	Dimensioni	<i>Dimensions</i>	Abmessungen	<i>Dimensions</i>	110

**MOTORI ELETTRICI  
ELECTRIC MOTORS  
ELEKTROMOTOREN  
MOTEURS ELECTRIQUES**

M1	Simbologia e unità di misura	<i>Symbols and units of measure</i>	Symbole und Maßeinheiten	<i>Symboles et unités de mesure</i>	144
M2	Caratteristiche generali	<i>General characteristics</i>	Allgemeine Eigenschaften	<i>Caractéristiques générales</i>	145
M3	Caratteristiche meccaniche	<i>Mechanical characteristics</i>	Mechanische Eigenschaften	<i>Caractéristiques mécaniques</i>	147
M4	Caratteristiche elettriche	<i>Electrical characteristics</i>	Elektrische Eigenschaften	<i>Caractéristiques électriques</i>	152
M5	Motori asincroni autofrenanti	<i>Asynchronous brake motors</i>	Bremsmotoren	<i>Moteurs asynchrones freins</i>	159
M6	Motori autofrenanti in c.c., tipo BN_FD	<i>DC brake motors type BN_FD</i>	Drehstrom-Bremsmotoren mit Gleichstrombremse: typ BN_FD	<i>Moteurs frein en c.c. type BN_FD</i>	160
M7	Motori autofrenanti in c.a., tipo BN_FA	<i>AC brake motors type BN_FA</i>	Wechselstrombremsmotoren: typ BN_FA	<i>Moteurs frein en c.a. type BN_FA</i>	160
M8	Motori autofrenanti in c.a., tipo BN_BA	<i>AC brake motors type BN_BA</i>	Drehstrom-Bremsmotoren mit Wechselstrombremse: typ BN_BA	<i>Moteurs frein en c.a. type BN_BA</i>	169
M9	Sistemi di sblocco freno	<i>Brake release systems</i>	Brenslüfthebel	<i>Systemes de déblocage frein</i>	173
M10	Opzioni	<i>Options</i>	Optionen	<i>Options</i>	175
M11	Dati tecnici motori	<i>Motor rating charts</i>	Motorenauswahl-tabellen	<i>Données techniques des moteurs</i>	181
M12	Dimensioni	<i>Dimensions</i>	Abmessungen	<i>Dimensions</i>	197

Revisions  
L'indice di revisione del catalogo è riportato a pag. 210.  
Al sito [www.bonfiglioli.com](http://www.bonfiglioli.com) sono disponibili i cataloghi con le revisioni aggiornate.

Revisions  
Refer to page 210 for the catalogue revision index.  
Visit [www.bonfiglioli.com](http://www.bonfiglioli.com) to search for catalogues with up-to-date revisions.

Änderungen  
Das Revisionsverzeichnis des Katalogs wird auf Seite 210 wiedergegeben. Auf unserer Website [www.bonfiglioli.com](http://www.bonfiglioli.com) werden die Kataloge in ihrer letzten, überarbeiteten Version angeboten.

Révisions  
Le sommaire de révision du catalogue est indiqué à la page 210.  
Sur le site [www.bonfiglioli.com](http://www.bonfiglioli.com) des catalogues avec les dernières révisions sont disponibles.

**1 - SIMBOLOGIA E UNITÀ  
DI MISURA**
**1 - SYMBOLS AND UNITS  
OF MEASURE**
**1 - SYMBOLE UND  
MAßEINHEITEN**
**1 - SYMBOLES ET UNITES  
DE MESURE**

Simb. Symb.	U.m. Meße- inh.	Descrizione	Description	Beschreibung	Description
$A_{N 1, 2}$	[N]	Carico assiale nominale	Permissible axial force	Nenn-Axialbelastung	Charge axiale nominale
$f_s$	–	Fattore di servizio	Service factor	Betriebsfaktor	Facteur de service
$f_T$	–	Fattore termico	Thermal factor	Temperaturfaktor	Facteur thermique
$f_{TP}$	–	Fattore di temperatura	Temperature factor	Wärmefaktor	Facteur de température
$i$	–	Rapporto di trasmissione	Gear ratio	Übersetzung	Rapport de réduction
$I$	–	Rapporto di intermittenza	Cyclic duration factor	Relative Einschaltdauer	Rapport d'intermittence
$J_C$	[Kgm <sup>2</sup> ]	Momento di inerzia carico	Mass moment of inertia to be driven	Massenträgheitsmoment der externen Massen	Moment d'inertie de la charge
$J_M$	[Kgm <sup>2</sup> ]	Momento di inerzia motore	Motor mass moment of inertia	Motorträgheitsmoment	Moment d'inertie du moteur
$J_R$	[Kgm <sup>2</sup> ]	Momento di inerzia riduttore	Mass moment of inertia for the gear unit	Getriebeträgheitsmoment	Moment d'inertie du réducteur
$K$	–	Fattore di accelerazione delle masse	Mass acceleration factor	Massenbeschleunigungsfaktor	Facteur d'accélération des masses
$K_r$	–	Costante di trasmissione	Transmission element factor	Belastungsfaktor der Radiallast	Constante de transmission
$M_{1, 2}$	[Nm]	Coppia	Torque	Drehmoment	Couple
$M_c$	[Nm]	Coppia di calcolo	Calculated torque	Berechnetes Drehmoment	Couple de calcul
$M_n$	[Nm]	Coppia nominale	Rated torque	Nennmoment	Couple nominal
$M_r$	[Nm]	Coppia richiesta	Torque demand	Benötigtes Drehmoment	Couple nécessaire
$n_{1, 2}$	[min <sup>-1</sup> ]	Velocità	Speed	Abtriebsdrehzahl	Vitesse
$P_{1, 2}$	[kW]	Potenza	Power	Leistung	Puissance
$P_{N 1, 2}$	[kW]	Potenza nominale	Rated power	Nennleistung	Puissance nominale
$P_{R 1, 2}$	[kW]	Potenza richiesta	Power demand	Benötigte Leistung	Puissance nécessaire
$R_C$	[N]	Carico radiale di calcolo	Calculated radial force	Berechnete Axialbelastung	Charge radiale de calcul
$R_N$	[N]	Carico radiale nominale	Permissible overhung load	Zulässige Radialbelastung	Charge radiale nominale
$S$	–	Fattore di sicurezza	Safety factor	Sicherheitsfaktor	Facteur de sécurité
$t_a$	[°C]	Temperatura ambiente	Ambient temperature	Umgebungstemperatur	Température ambiante
$t_f$	[min]	Tempo di funzionamento a carico costante	Work time under constant load	Betriebszeit während nennbetrieb	Temps de fonctionnement à charge constante
$t_r$	[min]	Tempo di riposo	Rest time	Stillstandszeit	Temps de repos
$\eta_d$	–	Rendimento dinamico	Dynamic efficiency	Dynamischer Wirkungsgrad	Rendement dynamique
$\eta_s$	–	Rendimento statico	Static efficiency	Statischer Wirkungsgrad	Rendement statique

1 valore riferito all'albero veloce

1 value applies to input shaft

1 Werte beziehen sich auf die Antriebswelle

1 valeurs pour l'arbre rapide

2 valore riferito all'albero lento

2 value applies to output shaft

2 Werte beziehen sich auf die Abtriebswelle

2 valeurs pour l'arbre lent



Questo simbolo riporta i riferimenti angolari per l'indicazione della direzione del carico radiale (l'albero è visto di fronte).



This symbol refers to the angle the overhung load applies (viewing from drive end).



Dieses Symbol gibt die Winkelbezugswerte für die Angabe der Richtung der Radialkräfte an (Stirnansicht der Welle).



Ce symbole présente les références angulaires pour l'indication de la direction de la charge radiale (l'arbre est vu de face).



Simbolo riferito al peso dei riduttori e dei motoriduttori. I valori riportati nelle tabelle dei motoriduttori sono comprensivi sia del peso del motore a 4 poli sia del peso del lubrificante contenuto, qualora previsto da BONFIGLIOLI RIDUTTORI.



Symbol refers to weight of gearmotors and speed reducers. Figure for gearmotors incorporates the weight of the 4-pole motor and for life lubricated units, where applicable, the weight of the oil.



Symbol für das Gewicht der Getriebe und der Getriebemotoren. Die in der Getriebemotoren-Tabelle genannten Werte schließen das Gewicht des vierpoligen Motors und die eingefüllte Schmierstoffmenge ein, sofern von BONFIGLIOLI RIDUTTORI vorgesehen.



Symbole se référant aux poids des réducteurs et des motoréducteurs. Les valeurs indiquées dans les tableaux des motoréducteurs comprennent tant le poids du moteur à 4 pôles que le poids du lubrifiant contenu, lorsque prévu par BONFIGLIOLI RIDUTTORI.

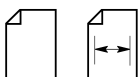

Il simbolo identifica la pagina alla quale può essere reperita l'informazione.



The symbol shows the page the information can be sorted from.

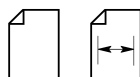

Das Symbol Kennzeichnet die Seite, auf die die Information gefunden werden kann.



Le symbole identifie la page à laquelle l'on peut trouver l'information.

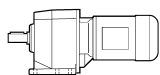

Motoriduttore con motore integrato.

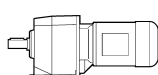

Gearmotor with compact motor.

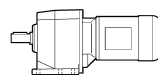

Getriebemotor mit Kompaktmotor.

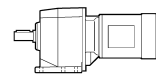

Motoréducteur avec moteur compact.



Motoriduttore abbinato con motore a standard IEC



Gearmotor with IEC motor.



Getriebemotor mit IEC-Motor.



Motoréducteur avec moteur normalisé CEI.



Riduttore predisposto per abbinamento con motore a standard IEC.

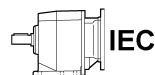

Gear unit with IEC motor interface.

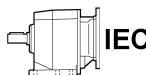

Getriebe vorbereitet für IEC-motor.

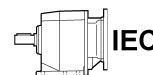

Réducteur prédisposé pour liaison a moteur IEC.

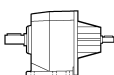

Riduttore dotato di albero veloce cilindrico.

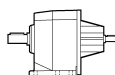

Speed reducer with solid input shaft.

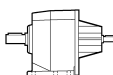

Getriebe mit zylindrischer Antriebswelle.

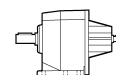

Réducteur avec arbre rapide Cyllindrique.

**INFORMAZIONI GENERALI****GENERAL INFORMATION****ALLGEMEINEINFORMATIONEN****INFORMATIONS GENERALES****2 - COPPIA****2 - TORQUE****2 - ABTRIEBSMOMENT****2 - COUPLE****Coppia nominale**  
 $M_{n2}$  [Nm]

È la coppia trasmissibile in uscita con carico continuo uniforme, riferita alla velocità in ingresso  $n_1$  e a quella corrispondente in uscita  $n_2$ .  
È calcolata in base ad un fattore di servizio  $f_s = 1$ .

**Rated torque**  
 $M_{n2}$  [Nm]

*The torque that can be transmitted continuously through the output shaft, with the gear unit operated under a service factor  $f_s = 1$ .  
Rating is speed sensitive.*

**Nenn-Drehmoment**  
 $M_{n2}$  [Nm]

Dies ist das an der Abtriebswelle übertragbare Drehmoment bei gleichförmiger Dauerbelastung bezogen auf die Antriebsdrehzahl  $n_1$  und die entsprechende Abtriebsdrehzahl  $n_2$ .  
Das Drehmoment wird auf Grundlage eines Betriebsfaktor  $f_s = 1$  berechnet.

**Couple nominal**  
 $M_{n2}$  [Nm]

*C'est le couple transmissible en sortie avec une charge continue uniforme se référant à la vitesse en entrée  $n_1$  et à celle correspondante en sortie  $n_2$ .  
Il est calculé sur la base d'un facteur de service  $f_s = 1$ .*

**Coppia richiesta**  
 $M_{r2}$  [Nm]

Rappresenta la coppia richiesta dall'applicazione e dovrà sempre essere uguale o inferiore alla coppia in uscita nominale  $M_{n2}$  del riduttore scelto.

**Required torque**  
 $M_{r2}$  [Nm]

*The torque demand based on application requirement.  
It must always be equal to or less than torque  $M_{n2}$  the gearbox under study is rated for.*

**Verlangtes Drehmoment**  
 $M_{r2}$  [Nm]

Dies ist das von der Anwendung verlangte Drehmoment, das stets kleiner oder gleich dem Nenn-Abtriebsmoment  $M_{n2}$  des gewählten Getriebes sein muß.

**Couple requis**  
 $M_{r2}$  [Nm]

*Il représente le couple requis par l'application et devra toujours être inférieur ou égal au couple en sortie nominal  $M_{n2}$  du réducteur choisi.*

**Coppia di calcolo**  
 $M_{c2}$  [Nm]

È il valore di coppia da utilizzare per la selezione del riduttore considerando la coppia richiesta  $M_{r2}$  e il fattore di servizio  $f_s$  ed è dato dalla formula:

**Calculated torque**  
 $M_{c2}$  [Nm]

*Computational torque value to be used when selecting the gearbox.  
It is calculated considering the required torque  $M_{r2}$  and service factor  $f_s$ , as per the equation here after:*

**Soll-Drehmoment**  
 $M_{c2}$  [Nm]

Dies ist das bei der Wahl des Getriebes zugrundezulegende Drehmoment, wobei das übertragene Drehmoment  $M_{r2}$  und der Betriebsfaktor  $f_s$  zu berücksichtigen sind; das Soll-Drehmoment wird mit folgender Gleichung berechnet:

**Couple de calcul**  
 $M_{c2}$  [Nm]

*C'est la valeur de couple à utiliser pour la sélection du réducteur en considérant le couple requis  $M_{r2}$  et le facteur de service  $f_s$  et s'obtient avec la formule:*

$$M_{c2} = M_{r2} \cdot f_s < M_{n2} \quad (1)$$

**3 - POTENZA****3 - POWER****3 - LEISTUNG****3 - PUISSANCE****Potenza nominale in entrata**  $P_{n1}$  [kW]

Nelle tabelle di selezione dei riduttori è la potenza applicabile in entrata riferita alla velocità  $n_1$ , considerando un fattore di servizio  $f_s = 1$ .

**Rated power**  
 $P_{n1}$  [kW]

*In the gearbox selection charts this is the power applicable to input shaft, based on input speed  $n_1$  and corresponding to service factor  $f_s = 1$ .*

**Leistung Antriebswelle**  
 $P_{n1}$  [kW]

In den Tabellen für die Wahl der Getriebe ist die an der Antriebswelle übertragbare Leistung auf die Drehzahl  $n_1$  bezogen und es wurde ein Betriebsfaktor  $f_s = 1$  angenommen.

**Puissance en entrée**  
 $P_{n1}$  [kW]

*Dans les tableaux de sélection des réducteurs, c'est la puissance applicable en entrée se rapportant à la vitesse  $n_1$  et en considérant un facteur de service  $f_s = 1$ .*



**4 - POTENZA TERMICA**  
**P<sub>t</sub> [kW]**

P<sub>t</sub> è il valore che indica il limite termico del riduttore e rappresenta la potenza trasmissibile in servizio continuo, e alla temperatura ambiente t<sub>a</sub>= 20 °C, senza che si producano danneggiamenti negli organi del riduttore o degradamenti del lubrificante. Vedi tab. (A1).

Nel caso di servizio intermittente, o di temperatura ambiente diversa da 20 °C, il valore di P<sub>t</sub> deve essere corretto per mezzo del fattore f<sub>t</sub>, espresso dalla tabella (A2), ossia P<sub>t</sub>' = P<sub>t</sub> x f<sub>t</sub>.

Infine, per riduttori con più di due riduzioni e/o con rapporto i > 45 la verifica della potenza termica non è necessaria in quanto quest'ultima è certamente superiore alla potenza meccanica trasmissibile.

**4 - THERMAL CAPACITY**  
**P<sub>t</sub> [kW]**

*P<sub>t</sub> is the power that can be transmitted through the gear unit, under a continuous duty and an ambient temperature of 20 °C, without resulting into damage of the inner parts or degradation of the lubricant properties. Refer to chart (A1) for specific kW ratings.*

*In case of intermittent duty, or an operating ambient temperature other than the rated 20 °C, the P<sub>t</sub> value should be adjusted through the factor f<sub>t</sub>, obtained from chart (A2), as per the following equation: P<sub>t</sub>' = P<sub>t</sub> x f<sub>t</sub>.*

*Gear units featuring more than 2 reductions and/or a gear ratio greater than i = 45 do not normally require the thermal limit to be checked as in these cases the thermal rating usually exceeds the mechanical rating.*

**4 - THERMISCHE GRENZ-LEISTUNG** P<sub>t</sub> [kW]

P<sub>t</sub> steht für den Wert der Wärmegrenzleistung des Getriebes und gibt die im Dauerbetrieb und bei einer Umgebungstemperatur t<sub>a</sub>=20 °C übertragbare Leistung an, ohne daß sich daraus Schäden an den Getriebeorganen oder ein Verfall des Schmiermittels ergeben. Siehe Tab. (A1). Bei einem Aussetzbetrieb oder bei verschiedener Umgebungstemperatur als 20°C muß der Wert P<sub>t</sub> über den Faktor f<sub>t</sub> korrigiert werden, der in der Tabelle (A2) aufgeführt wird bzw. P<sub>t</sub>' = P<sub>t</sub> x f<sub>t</sub>

Bei Getrieben mit mehr als zwei Untersetzungsstufen und/oder einem Verhältnis von i > 45 ist die Kontrolle der thermischen Leistung nicht erforderlich, da sie sicher oben der mechanisch übertragbaren Leistung liegt.

**4 - PUISSANCE THERMIQUE**  
**P<sub>t</sub> [kW]**

*P<sub>t</sub> est la valeur qui indique la limite thermique du réducteur et représente la puissance transmissible en service continu, et à une température ambiante t<sub>a</sub>=20 °C, sans apparition de dommages au niveau des organes du réducteur ou de dégradations du lubrifiant. Voir tab. (A1). En cas de service intermittent ou de température ambiante différente de 20°C, la valeur de P<sub>t</sub> doit être corrigée au moyen du facteur f<sub>t</sub>, exprimé dans le tableau (A2), à savoir: P<sub>t</sub>' = P<sub>t</sub> x f<sub>t</sub>*

*Enfin, pour les réducteurs ayant plus de deux réductions et/ou un rapport i > 45, la vérification de la puissance thermique n'est pas nécessaire car elle est certainement supérieure à la puissance mécanique transmissible.*

(A1)

P <sub>t</sub> [kW] 20 °C		
	n <sub>1</sub> = 1400 min <sup>-1</sup>	n <sub>1</sub> = 2800 min <sup>-1</sup>
<b>C 05 2</b>	—	—
<b>C 11 2</b>	—	—
<b>C 21 2</b>	—	—
<b>C 31 2</b>	—	4.5
<b>C 35 2</b>	6.5	5.0
<b>C 41 2</b>	8.0	6.0
<b>C 51 2</b>	11.0	7.8
<b>C 61 2</b>	14.0	10.0
<b>C 70 2</b>	21	16.0
<b>C 80 2</b>	32	24
<b>C 90 2</b>	43	32
<b>C 100 2</b>	59	42

(A2)

f <sub>t</sub>					
t <sub>a</sub> [°C]	Servizio continuo Continuous duty Dauerbetrieb Service continu	Servizio intermittente / Intermittent duty / Aussetzbetrieb / Service intermittent			
		Grado di intermittenza / Degree of intermittence / Relative Einschaltdauer / Degrè d'intermittence			
		[ I ]			
		80%	60%	40%	20%
40	0.80	1.1	1.3	1.5	1.6
30	0.85	1.3	1.5	1.6	1.8
20	1.0	1.5	1.6	1.8	2.0
10	1.15	1.6	1.8	2.0	2.3



Il grado di intermittenza (I)% è dato dal rapporto fra il tempo di funzionamento a carico  $t_f$  e il tempo totale ( $t_f + t_r$ ), espresso in percentuale.

Where cyclic duration factor (I)% is the relationship of operating time under load  $t_f$  to total time ( $t_f + t_r$ ) expressed as a percentage.

Wobei die Einschaltdauer (I)% von dem Verhältnis zwischen Betriebszeit unter Last  $t_f$  und der Gesamtbetriebszeit ( $t_f + t_r$ ), ausgedrückt in Prozenten, gegeben wird.

Où le degré d'intermittence (I)% est fourni par le rapport entre le temps de fonction en charge et le temps total ( $t_f + t_r$ ) exprimé en pourcentage.

$$I = \frac{t_f}{t_f + t_r} \cdot 100 \quad (2)$$

La condizione da verificare è:

The condition to be verified is:

Die durchzuführende Kontrolle ist:

La vérification à faire sera la suivante:

$$P_{r1} \leq P_t \times f_t \quad (3)$$

#### 5 - RENDIMENTO

#### 5 - EFFICIENCY

#### 5 - WIRKUNGSGRAD

#### 5 - RENDEMENT

Rendimento dinamico  $\eta_d$

Dynamic efficiency  $\eta_d$

Dynamischer Wirkungsgrad  $\eta_d$

Rendement dynamique  $\eta_d$

È dato dal rapporto fra la potenza in uscita  $P_2$  e quella in entrata  $P_1$  secondo la relazione:



Obtained from the relationship of delivered power  $P_2$  to input power  $P_1$ , according to the following equation:

Er ist gegeben durch das Verhältnis der Abtriebsleistung  $P_2$  zur Antriebsleistung  $P_1$ :

Il est donné par le rapport entre la puissance en sortie  $P_2$  et celle en entrée  $P_1$ :

$$\eta_d = \frac{P_2}{P_1} \cdot 100 \quad [\%] \quad (4)$$

(A3)

	2 x 	3 x 	4 x 
$\eta_d$	95%	93%	90%

#### 6 - RAPPORTO DI RIDUZIONE $i$

#### 6 - GEAR RATIO $i$

#### 6 - GETRIEBEÜBERSETZUNG $i$

#### 6 - RAPPORT DE REDUCTION $i$

Il valore del rapporto di riduzione della velocità, identificato con il simbolo  $[i]$ , è espresso tramite il rapporto fra le velocità all'albero veloce e lento del riduttore e riassunto nell'espressione:

The value for the gear ratio is referred to with the letter  $[i]$  and calculated through the relationship of the input speed  $n_1$  to the output speed  $n_2$ :

Die Übersetzung des Getriebes wird mit dem Buchstaben  $[i]$  bezeichnet und ist folgendermaßen definiert:

Le rapport de réduction est identifiée par la lettre  $[i]$  et son calcul s'effectue à partir de la vitesse d'entrée  $n_1$  et de la vitesse de sortie  $n_2$  en utilisant la relation suivante :

$$i = \frac{n_1}{n_2} \quad (5)$$



Il rapporto di riduzione è solitamente un numero decimale che viene rappresentato nel catalogo con una sola cifra decimale, o nessuna nel caso di  $i > 1000$ .

Se si è interessati a conoscere il numero in tutte le componenti decimali consultare il Servizio Tecnico di Bonfiglioli Riduttori.

*The gear ratio is usually a decimal number which in this catalogue is truncated at one digit after the comma (no decimals for  $i > 1000$ ).*

*If interested in knowing the exact value please consult Bonfiglioli's Technical Service.*

In diesem Katalog wird die Übersetzung mit einer Stelle hinter dem Komma angegeben, bei Übersetzungen  $> 1000$  ohne Dezimalstelle.

Wenn genaue Angaben zur Übersetzung benötigt werden, wenden sie sich bitte an den technischen Service von Bonfiglioli Riduttori.

*Dans le catalogue, le rapport de réduction a une précision d'un chiffre après la virgule (sauf pour  $i > 1000$ ).*

*Si une plus grande précision est nécessaire, contacter le Service Technique de Bonfiglioli.*

## 7 - VELOCITÀ ANGOLARE

**Velocità in entrata**  
 $n_1$  [ $\text{min}^{-1}$ ]

È la velocità relativa al tipo di motorizzazione scelta; i valori di catalogo si riferiscono alle velocità dei motori elettrici comunemente usati a singola e doppia polarità.

Se il riduttore riceve il moto da una trasmissione in entrata, è sempre preferibile adottare velocità inferiori a  $1400 \text{ min}^{-1}$  al fine di garantire condizioni ottimali di funzionamento.

Velocità in entrata superiori sono ammesse considerando il naturale declassamento della coppia nominale  $M_{n2}$  del riduttore.

## 7 - ANGULAR VELOCITY

**Input speed**  
 $n_1$  [ $\text{min}^{-1}$ ]

*The speed is related to the prime mover selected. Catalogue values refer to speed of either single or double speed motors that are common in the industry.*

*If the gearbox is driven by an external transmission it is recommended to operate it with a speed of  $1400 \text{ min}^{-1}$ , or lower, in order to optimise operating conditions and lifetime.*

*Higher input speeds are permitted, however in this case consider that torque rating  $M_{n2}$  is affected adversely.*

*Please consult a Bonfiglioli representative.*

## 7 - DREHZAHL

**Drehzahl Antriebswelle**  
 $n_1$  [ $\text{min}^{-1}$ ]

Dies ist die vom gewählten Motortyp abhängige Drehzahl. Die Katalogangaben beziehen sich auf die Drehzahl von allgemein üblichen eintourigen Elektromotoren oder von polumschaltbaren Elektromotoren.

Um optimale Betriebsbedingungen zu gewährleisten, ist stets eine Antriebsdrehzahl unter  $1400 \text{ min}^{-1}$  zu empfehlen.

Höhere Antriebsdrehzahlen sind zulässig, wobei die zwangsläufige Herabsetzung des Nenn-Abtriebsdrehmoments  $M_{n2}$  des Getriebes zu berücksichtigen ist.

## 7 - VITESSE ANGULAIRE

**Vitesse d'entrée**  
 $n_1$  [ $\text{min}^{-1}$ ]

*C'est la vitesse relative au type de motorisation choisie. Les valeurs de catalogue se réfèrent aux vitesses des moteurs électriques à simple et double polarité communément utilisés.*

*Si le réducteur reçoit le mouvement d'une transmission en entrée, il est toujours préférable d'adopter des vitesses inférieures à  $1400 \text{ min}^{-1}$  afin de garantir des conditions optimales de fonctionnement.*

*Des vitesses d'entrée supérieures sont admises en considérant le déclassement naturel du couple nominal  $M_{n2}$  du réducteur.*

**Velocità in uscita**  
 $n_2$  [ $\text{min}^{-1}$ ]

È in funzione della velocità in entrata  $n_1$  e del rapporto di riduzione  $i$  secondo la relazione:

**Output speed**  
 $n_2$  [ $\text{min}^{-1}$ ]

*The output speed value  $n_2$  is calculated from the relationship of input speed  $n_1$  to the gear ratio  $i$ , as per the following equation:*

**Abtriebsdrehzahl**  
 $n_2$  [ $\text{min}^{-1}$ ]

Sie ist abhängig von der Antriebsdrehzahl  $n_1$  und dem Übersetzungs  $i$  nach folgender Gleichung:

**Vitesse en sortie**  
 $n_2$  [ $\text{min}^{-1}$ ]

*Elle varie en fonction de la vitesse d'entrée  $n_1$  et du rapport de réduction  $i$  selon l'équation:*

$$n_2 = \frac{n_1}{i} \quad (6)$$

**8 - MOMENTO D'INERZIA**  
 $J_r$  [ $\text{Kgm}^2$ ]

I momenti d'inerzia indicati a catalogo sono riferiti all'asse di entrata del riduttore per cui, nel caso di accoppiamento diretto, sono già rapportati alla velocità del motore.

**8 - MOMENT OF INERTIA**  
 $J_r$  [ $\text{Kgm}^2$ ]

*Moments of inertia specified in the catalogue refer to the gear unit input axis. They are therefore related to motor speed, in the case of direct motor mounting.*

**8 - TRÄGHEITSMOMENT**  
 $J_r$  [ $\text{Kgm}^2$ ]

Die im Katalog angegebenen Trägheitsmomente sind auf die Antriebswelle des Getriebes bezogen und daher im Falle einer direkten Verbindung schon zur Motordrehzahl in Beziehung gesetzt.

**8 - MOMENT D'INERTIE**  
 $J_r$  [ $\text{Kgm}^2$ ]

*Les moments d'inertie indiqués dans le catalogue se réfèrent à l'axe d'entrée du réducteur par conséquent, dans le cas d'accouplement direct, ils se rapportent déjà à la vitesse du moteur.*

**9 - FATTORE DI SERVIZIO  $f_s$** **9 - SERVICE FACTOR  $f_s$** **9 - BETRIEBSFAKTOR  $f_s$** **9 - FACTEUR DE SERVICE  $f_s$** 

Il fattore di servizio è il parametro che traduce in un valore numerico la gravosità del servizio che il riduttore è chiamato a svolgere, tenendo conto, benché con inevitabile approssimazione, del funzionamento giornaliero, della variabilità del carico e di eventuali sovraccarichi, connessi con la specifica applicazione del riduttore.

Nel grafico (A4) più sotto riportato il fattore di servizio si ricava, dopo aver selezionato la colonna relativa alle ore di funzionamento giornaliere, per intersezione fra il numero di avviamenti orari e una fra le curve K1, K2 e K3.

Le curve K\_ sono associate alla natura del servizio (approssimativamente: uniforme, medio e pesante) tramite il fattore di accelerazione delle masse K, legato al rapporto fra le inerzie delle masse condotte e del motore.

Indipendentemente dal valore così ricavato del fattore di servizio, segnaliamo che esistono applicazioni fra le quali, a puro titolo di esempio i sollevamenti, per le quali il cedimento di un organo del riduttore potrebbe esporre il personale che opera nelle immediate vicinanze a rischio di ferimento.

Se esistono dubbi che l'applicazione possa presentare questa criticità vi invitiamo a consultare preventivamente il ns. Servizio Tecnico.

*This factor is the numeric value describing reducer service duty. It takes into consideration, with unavoidable approximation, daily operating conditions, load variations and overloads connected with reducer application.*

*In the graph (A4) below, after selecting proper "daily working hours" column, the service factor is given by intersecting the number of starts per hour and one of the K1, K2 or K3 curves.*

*K\_ curves are linked with the service nature (approximately: uniform, medium and heavy) through the acceleration factor of masses K, connected to the ratio between driven masses and motor inertia values.*

*Regardless of the value given for the service factor, we would like to remind that in some applications, which for example involve lifting of parts, failure of the reducer may expose the operators to the risk of injuries.*

*If in doubt, please contact our Technical Service Department.*

Beim Betriebsfaktor handelt es sich um den Parameter, der die Betriebsbelastung, die das Getriebe aushalten muss, in einem Wert ausdrückt. Dabei berücksichtigt er, auch wenn nur mit einer unvermeidbaren Annäherung, den täglichen Einsatz, die unterschiedlichen Belastungen und eventuelle Überbelastungen, die mit der spezifischen Applikation des Getriebes verbunden sind. Der nachstehenden Grafik (A4) kann, nach der Wahl der entsprechenden Spalte mit der Angabe der täglichen Betriebsstunden der Betriebsfaktor entnommen werden, indem man die Schnittstelle zwischen der stündlichen Schaltungen und einer der Kurven K1, K2 und K3 sucht. Die mit K\_ gekennzeichneten Kurven sind über den Beschleunigungsfaktor der Massen K an die Betriebsart gekoppelt (annähernd: gleichmäßige, mittlere oder starke Belastung), der wiederum an das Verhältnis zwischen Trägheitsmoment der angetriebenen Massen und dem des Motors gebunden ist. Unabhängig von dem so erhaltenen Betriebsfaktor, möchten wir Sie darauf hinweisen, dass es Applikationen gibt, unter denen beispielsweise auch die Hebefunktionen zu finden sind, bei denen das Nachgeben eines Getriebeorgans, das in dessen Nähe arbeitende Personal einer Verletzungsgefahr aussetzen könnte. Sollten daher Zweifel darüber bestehen, ob die entsprechende Applikation sich in diesem Bezug als kritisch erweist, bitten wir Sie sich zuvor mit unseren Technischen Kundendienst in Verbindung zu setzen.

*Le facteur de service est le paramètre qui traduit en une valeur numérique la difficulté du service que le réducteur est appelé à effectuer en tenant compte, avec une approximation inévitable, du fonctionnement journalier, de la variabilité de la charge et des éventuelles surcharges liées à l'application spécifique du réducteur.*

*Sur le graphique (A4) ci-dessous, le facteur de service peut être trouvé, après avoir sélectionné la colonne relative aux heures de fonctionnement journalier, à l'intersection entre le nombre de démarrages horaires et l'une des courbes K1, K2 et K3.*

*Les courbes K\_ sont associées à la nature du service (approximativement : uniforme, moyen et difficile) au moyen du facteur d'accélération des masses K, lié au rapport entre les inerties des masses conduites et le moteur.*

*Indépendamment de la valeur du facteur de service ainsi trouvée, nous signalons qu'il existe des applications parmi lesquelles, à titre d'exemple, les levages, pour lesquels la rupture d'un organe du réducteur pourrait exposer le personnel opérant à proximité immédiate à des risques de lésion.*

*En cas de doute concernant les risques éventuels de l'application, nous vous conseillons de contacter préalablement notre Service Technique.*

(A4)

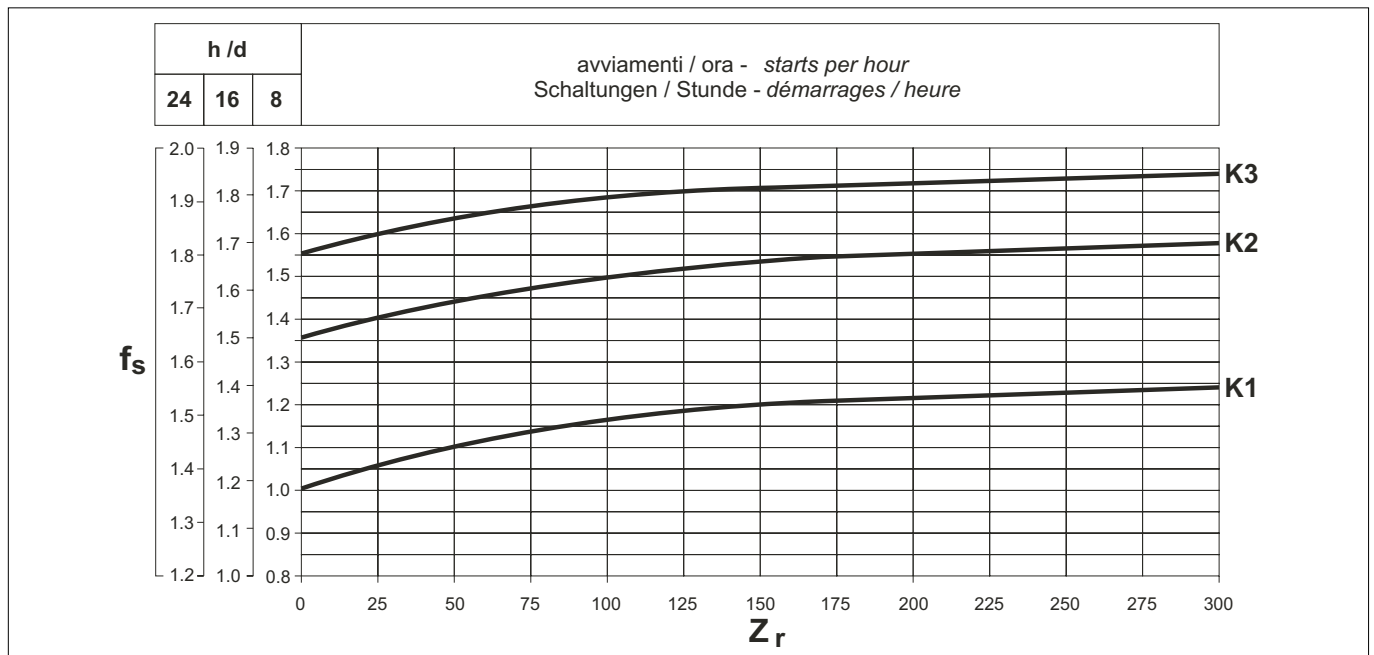



**Fattore di accelerazione delle masse, K****Acceleration factor of masses, K****Beschleunigungsfaktor der Massen, K****Facteur d'accélération des masses, K**

Il parametro serve a selezionare la curva relativa al particolare tipo di carico. Il valore è dato dal rapporto:

*This parameter serves for selecting the right curve for the type of load. The value is given by the following ratio:*

Dieser Parameter dient der Wahl der Kurve, die sich auf die jeweilige Belastungsart bezieht. Der Wert ergibt sich aus folgender Formel:

*Le paramètre sert à sélectionner la courbe relative au type de charge particulier. La valeur est obtenue par l'équation :*

$$K = \frac{J_c}{J_m} \quad (7)$$

dove:

where:

wobei:

où:

$J_c$  momento d'inerzia delle masse comandate, riferito all'albero del motore

$J_c$  *moment of inertia of driven masses referred to motor driving shaft*

$J_c$  Trägheitsmoment der angetriebenen Massen, bezogen auf die Motorwelle

$J_c$  *moment d'inertie des masses commandées se référant à l'arbre du moteur*

$J_m$  momento d'inerzia del motore

$J_m$  *moment of inertia of motor*

$J_m$  Trägheitsmoment des Motors

$J_m$  *moment d'inertie du moteur*

$K \leq 0.25$  – curva **K1**  
carico uniforme

$K \leq 0.25$  – curve **K1**  
*uniform load*

$K \leq 0.25$  – Kurve **K1**  
Gleichmäßige Belastung

$K \leq 0.25$  – courbe **K1**  
*charge uniforme*

$0.25 < K \leq 3$  – curva **K2**  
carico con urti moderati

$0.25 < K \leq 3$  – curve **K2**  
*moderate shock load*

$0.25 < K \leq 3$  – Kurve **K2**  
Belastung mit mäßigen Stößen

$0.25 < K \leq 3$  – courbe **K2**  
*charge avec chocs modérés*

$3 < K \leq 10$  – curva **K3**  
carico con forti urti

$3 < K \leq 10$  – curve **K3**  
*heavy shock load*

$3 < K \leq 10$  – Kurve **K3**  
Belastung mit starken Stößen

$3 < K \leq 10$  – courbe **K3**  
*charge avec chocs importants*

Per valori di  $K > 10$  invitiamo a consultare il nostro Servizio Tecnico.

*For K values > 10, please contact our Technical Service.*

Bei Werten  $K > 10$  bitten wir Sie, sich mit unserem Technischen Kundendienst in Verbindung zu setzen.

*Pour des valeurs de  $K > 10$ , nous vous conseillons de contacter notre Service Technique.*

**10 - MANUTENZIONE****10 - MAINTENANCE****10 - WARTUNG****10 - ENTRETIEN**

I riduttori forniti con lubrificazione permanente non necessitano di sostituzioni periodiche dell'olio.

*Life lubricated gearboxes do not require any periodical oil changes.*

Die mit Dauerschmierung gelieferten Getriebe bedürfen periodische Ölwechsel.

*Les réducteurs fournis avec lubrification permanente n'ont besoin d'aucun remplacement périodique de huile.*

Per gli altri si consiglia di effettuare una prima sostituzione del lubrificante dopo circa 300 ore di funzionamento provvedendo ad un accurato lavaggio interno del gruppo con adeguate detergenti.

*For other types of gearboxes, the first oil change must take place after about 300 hours of operation, carefully flushing the gear unit using suitable detergents.*

Bei den übrigen Getrieben wird ein erster Ölwechsel nach ca. 300 Betriebsstunden empfohlen, wobei das Innere der Gruppe sorgfältig mit einem geeigneten Reinigungsmittel zu waschen ist.

*Pour les autres, nous conseillons d'effectuer une première vidange du lubrifiant après les 300 premières heures de fonctionnement en réalisant un lavage soigné à l'intérieur du groupe avec des produits détergents appropriés.*

Evitare di miscelare olii a base minerale con olii sintetici.

*Do not mix mineral oils with synthetic oils.*

Mineralöle nicht mit Syntheseölen mischen.

*Eviter de mélanger les huiles à base minérale avec des huiles synthétiques.*

Controllare periodicamente il livello del lubrificante effettuando la sostituzione indicativamente agli intervalli riportati nella tabella (A5).

*Check oil level regularly and change oil at the intervals shown in the table (A5).*

Den Ölstand regelmäßig kontrollieren. Die Ölwechsel in den in der Tabelle (A5) angegebenen Fristen durchführen.

*Contrôler périodiquement le niveau du lubrifiant en effectuant les vidanges conformément aux intervalles indiqués dans le tableau (A5).*

(A5)

Temperatura olio / Oil temperature Öltemperatur / Température huile [°C]	Intervallo di lubrificazione / Oil change interval Schmierfrist / Intervalle de lubrification [h]	
	olio minerale / mineral oil Mineralöl / huile minérale	olio sintetico / synthetic oil Syntheseöl / huile synthétique
< 65	8000	25000
65 - 80	4000	15000
80 - 95	2000	12500



11 - SELEZIONE

11 - SELECTION

11 - ANTRIEBSAUSWAHL

11 - SELECTION

Per selezionare correttamente un riduttore o un motoriduttore, è necessario disporre di alcuni dati fondamentali che sono sintetizzati nella tabella (A6). In particolare, essa potrà essere compilata ed inviata in copia al ns. Servizio Tecnico che provvederà alla ricerca della motorizzazione più idonea alla applicazione indicata.

Some fundamental data are necessary to assist the correct selection of a gearbox or gearmotor. The table below (A6) briefly sums up this information. To simplify selection, fill in the table and send a copy to our Technical Service which will select the most suitable drive unit for your application.

Um die Getriebe und Getriebe-motoren richtig auszuwählen zu können, muß man über einige grundlegende Daten verfügen, die wir in der Tabelle (A6) zusammengefaßt haben. Eine Kopie dieser vom Kunden ausgefüllten Tabelle kann an unseren Technischen Kundendienst geschickt werden, der dann die für die gewünschte Anwendung geeignete Auslegung wählt.

Pour sélectionner correctement un réducteur ou un motoréducteur, il est nécessaire de disposer de certaines données fondamentales que nous avons résumé dans le tableau (A6). En particulier, ce dernier pourra être rempli et retourné à notre service technique qui recherchera la motorisation la plus appropriée à l'application indiquée.

(A6)

Tipo di applicazione Type of application Anwendung Type d'application			
P <sub>2</sub>	Potenza in uscita a n <sub>2</sub> max Output power at n <sub>2</sub> max Abtriebsleistung bei n <sub>2</sub> max Puissance en sortie à n <sub>2</sub> maxi	.....kW	Senso di rotazione albero entrata (O-AO) (**) Input shaft rotation direction (CW-CCW) (**) Drehrichtung der Antriebswelle (U-GU) (**) Sens de rotation arbre entrée (H-AH) (**)
P <sub>2</sub> '	Potenza in uscita a n <sub>2</sub> min Output power at n <sub>2</sub> min Abtriebsleistung bei n <sub>2</sub> min Puissance en sortie à n <sub>2</sub> mini	.....kW	A <sub>c1</sub> Carico assiale su albero in uscita (+/-)(***) Thrust load on output shaft (+/-)(***) Axialkraft auf Abtriebswelle (+/-)(***) Charge axiale sur arbre de sortie (+/-)(***)
M <sub>2</sub>	Momento torcente in uscita a n <sub>2</sub> max Output torque at n <sub>2</sub> max Abtriebsdrehmoment bei n <sub>2</sub> max Moment de torsion en sortie à n <sub>2</sub> maxi	.....Nm	A <sub>c1</sub> Carico assiale su albero in entrata (+/-)(***) Thrust load on input shaft (+/-)(***) Axialkraft auf Antriebswelle (+/-)(***) Charge axiale sur arbre d'entrée (+/-)(***)
n <sub>2</sub>	Velocità di rotazione in uscita max Max.output speed Abtriebsdrehzahl max Vitesse de rotation maxi en sortie	.....min <sup>-1</sup>	J <sub>c</sub> Momento d'inerzia del carico Moment of inertia of the load Trägheitsmoment der Last Moment d'inertie de la charge
n <sub>2</sub> '	Velocità di rotazione in uscita min Min.output speed Abtriebsdrehzahl min Vitesse de rotation mini en sortie	.....min <sup>-1</sup>	t <sub>a</sub> Temperatura ambiente Ambient temperature Umgebungstemperatur Température ambiante
n <sub>1</sub>	Velocità di rotazione in entrata max Max.input speed Antriebsdrehzahl max Vitesse de rotation maxi en entrée	.....min <sup>-1</sup>	Altitudine sul livello del mare Altitude above sea level Höhe ü.d.M. Altitude au-dessus du niveau de la mer
n <sub>1</sub> '	Velocità di rotazione in entrata min Min.input speed Antriebsdrehzahl min Vitesse de rotation mini en entrée	.....min <sup>-1</sup>	Tipo di servizio in accordo a CEI Duty type to IEC norms Relative Einschaltdauer gemäß CEI Type de service selon CEI
R <sub>c2</sub>	Carico radiale su albero in uscita Radial load on output shaft Radialkraft auf Abtriebswelle Charge radiale sur arbre de sortie	.....N	Z Frequenza di avviamento Starting frequency Schaltungshäufigkeit Fréquence de démarrage
x <sub>2</sub>	Distanza di applicazione del carico (*) Load application distance (*) Abstand des Kraftangriffspunktes (*) Distance d'application de la charge (*)	.....mm	Tensione di alimentazione motore Motor voltage Nennspannung des Motors Tension de alimentation moteur
	Orientamento del carico in uscita Load orientation at output Orientierung der Last am Abtrieb Orientation de la charge en sortie		Tensione di alimentazione freno Brake voltage Nennspannung der Bremse Tension de alimentation frein
	Senso di rotazione albero uscita (O-AO) (**) Output shaft rotation direction (CW-CCW) (**) Drehrichtung der Abtriebswelle (U-GU) (**) Sens de rotation arbre sortie (H-AH) (**)	.....	Frequenza Frequency Frequenz Fréquence
R <sub>c1</sub>	Carico radiale su albero in entrata Radial load on input shaft Radialkraft auf Antriebswelle Charge radiale sur arbre d'entrée	.....N	M <sub>b</sub> Coppia frenante Brake torque Bremsmoment Couple de freinag
x <sub>1</sub>	Distanza di applicazione del carico (*) Load application distance (*) Abstand des Kraftangriffspunktes (*) Distance d'application de la charge (*)	.....mm	Grado di protezione motore Motor protection degree Schutzart des Motors Degré de protection moteur
	Orientamento del carico in entrata Load orientation at input Orientierung der Last am Antrieb Orientation de la charge en entrée		Classe di isolamento Insulation class Isolierstoffklasse Classe d'isolation

(\*) La distanza x<sub>1-2</sub> è quella compresa fra il punto di applicazione della forza e la battuta dell'albero (se non indicata, si considererà la forza agente sulla mezzeria della sporgenza dell'albero).  
 (\*\*) O = orario  
AO = antiorario  
 (\*\*\*) + = compressione  
- = trazione

(\*) Distance x<sub>1-2</sub> is between force application point and shaft shoulder (if not indicated the force acting at mid-point of the shaft extension will be considered).  
 (\*\*) CW = clockwise;  
CCW = counterclockwise  
 (\*\*\*) + = push  
- = pull

(\*) Der Abstand x<sub>1-2</sub> ist der Abstand vom Kraftangriffspunkt zum Wellenansatz (wenn nicht anders angegeben, wird davon ausgegangen, daß die Kraft auf der Mitte des Wellenendes angreift).  
 (\*\*) U = Uhrzeigersinn;  
GU = Gegenurzeigersinn  
 (\*\*\*) + = Druck  
- = Zug

(\*) La distance x<sub>1-2</sub> est celle comprise entre le point d'application de la force et l'épaulement de l'arbre (si non précisée l'on considèrera la force agissant au milieu de la saillie de l'arbre).  
 (\*\*) H = sens horaire;  
AH = sens antihoraire  
 (\*\*\*) + = compression  
- = traction



<b>Scelta dei motoriduttori</b>	<b>Selection of a gearmotor</b>	<b>Wahl des Getriebemotors</b>	<b>Sélection des motoréducteurs</b>
---------------------------------	---------------------------------	--------------------------------	-------------------------------------

- |   |   |   |   |
|---|---|---|---|
| <p>a) Determinare il fattore di servizio <math>f_s</math> in funzione del tipo di carico (fattore K), del numero di inserzioni/ora <math>Z_r</math> e del numero di ore di funzionamento.</p> <p>b) Dalla coppia <math>M_{r2}</math>, conoscendo <math>n_2</math> e il rendimento dinamico <math>\eta_d</math>, ricavare la potenza in entrata.</p> | <p>a) <i>Determine service factor <math>f_s</math> according to type of duty (factor K), number of starts per hour <math>Z_r</math> and hours of operation.</i></p> <p>b) <i>From values of torque <math>M_{r2}</math>, speed <math>n_2</math> and efficiency <math>\eta_d</math> the required input power can be calculated from the equation:</i></p> | <p>a) Den Betriebsfaktor <math>f_s</math> in Abhängigkeit von der Belastungsart (Faktor K), den Schaltungen /Stunde <math>Z_r</math> und den Betriebsstunden bestimmen.</p> <p>b) Aus dem Drehmoment <math>M_{r2}</math> mit Hilfe der bekannten Werte für <math>n_2</math> und dem dynamischen Wirkungsgrad <math>\eta_d</math> die Antriebsleistung ableiten.</p> | <p>a) <i>Déterminer le facteur de service <math>f_s</math> en fonction du type de charge (facteur K), du nombre d'insertions/heure <math>Z_r</math> et du nombre d'heures de fonctionnement.</i></p> <p>b) <i>A partir du couple <math>M_{r2}</math>, en connaissant <math>n_2</math> et le rendement dynamique <math>\eta_d</math>, calculer la puissance en entrée.</i></p> |
|---|---|---|---|

$P_{r1} = \frac{M_{r2} \cdot n_2}{9550 \cdot \eta_d} \quad [\text{kW}] \quad (8)$
---

- |  |   |  |  |
|--|---|--|--|
| <p>Il valore di <math>\eta_d</math> per lo specifico riduttore può essere ricavato dal paragrafo 5.</p> <p>c) Ricercare fra le tabelle dei dati tecnici motoriduttori quella corrispondente ad una potenza normalizzata <math>P_n</math> tale che:</p> | <p><i>Value of <math>\eta_d</math> for the captioned worm gear can be sorted out from paragraph 5.</i></p> <p>c) <i>Consult the gearmotor selection charts and locate the table corresponding to normalised power <math>P_n</math>.</i></p> | <p>Für das spezifische Getriebe kann der Wert <math>\eta_d</math> unter Paragraph 5 erhoben werden.</p> <p>c) Unter den Tabellen mit den Technischen Daten der Getriebemotoren die Tabelle auswählen, die folgender Leistung entspricht:</p> | <p><i>Il valeur de <math>\eta_d</math> pour le réducteur spécifique peut être calculée d'après les indications du paragraphe 5.</i></p> <p>c) <i>Rechercher parmi les tableaux des caractéristiques techniques des motoréducteurs celui correspondant à une puissance:</i></p> |
|--|---|--|--|

$P_n \geq P_{r1} \quad (9)$
-----------------------------

- |  |  |   |   |
|--|--|---|---|
| <p>Se non diversamente indicato, la potenza <math>P_n</math> dei motori riportata a catalogo si riferisce al servizio continuo S1. Per i motori utilizzati in condizioni diverse da S1, sarà necessario identificare il tipo di servizio previsto con riferimento alle Norme CEI 2-3/IEC 34-1. In particolare, per i servizi da S2 a S8 e per le grandezze motore uguali o inferiori a 132, è possibile ottenere una maggiorazione della potenza rispetto a quella prevista per il servizio continuo, pertanto la condizione da soddisfare sarà:</p> | <p><i>Unless otherwise specified, power <math>P_n</math> of motors indicated in the catalogue refers to continuous duty S1. For motors used in conditions other than S1, the type of duty required by reference to CEI 2-3/IEC 34-1 Standards must be mentioned. For duties from S2 to S8 in particular and for motor frame 132 or smaller, extra power output can be obtained with respect to continuous duty. Accordingly the following condition must be satisfied:</i></p> | <p>Wenn nicht anders angegeben, bezieht sich die im Katalog angegebene Leistung <math>P_n</math> der Motoren auf Dauerbetrieb S1. Bei Motoren, die unter anderen Bedingungen als S1 eingesetzt werden, muß die vorgesehen Betriebsart unter Bezug auf die CEI-Normen 2-3/IEC 34-1 bestimmt werden. Insbesondere kann man für die Betriebsarten S2 bis S8 (und für Motorbaugrößen gleich oder niedriger als 132) eine Überdimensionierung der Leistung relativ zu der für den Dauerbetrieb vorgesehenen Leistung erhalten; die zu erfüllende Bedingung ist dann:</p> | <p><i>Sauf indication contraire la puissance <math>P_n</math> des moteurs indiquée dans le catalogue se réfère à un service continu S1. Pour les moteurs utilisés dans des conditions différentes du service S1, il sera nécessaire d'identifier le type de service prévu en se référant aux normes CEI 2-3/IEC 34-1. En particulier, pour les services de type S2 à S8 ou pour les tailles de moteurs égales ou inférieures à 132 il est possible d'obtenir une majoration de la puissance par rapport à celle prévue pour le service continu. Par conséquent, la condition à satisfaire sera:</i></p> |
|--|--|---|---|

$P_n \geq \frac{P_{r1}}{f_m} \quad (10)$
--

- |  |  |  |   |
|--|--|--|---|
| <p>Il fattore di maggiorazione <math>f_m</math> è ricavabile dalla tabella (A7).</p> | <p><i>The adjusting factor <math>f_m</math> can be obtained from table (A7).</i></p> | <p>Der Überdimensionierungsfaktor <math>f_m</math> kann der Tabelle (A7) entnommen werden.</p> | <p><i>Le facteur de majoration <math>f_m</math> peut être obtenu en consultant le tableau (A7).</i></p> |
|--|--|--|---|



**Rapporto di intermittenza**

**Intermittence ratio**

**Relative Einschaltdauer**

**Rapport d'intermittence**

$$I = \frac{t_f}{t_f + t_r} \cdot 100 \quad (11)$$

$t_f$  = tempo di funzionamento a carico costante  
 $t_r$  = tempo di riposo

$t_f$  = work time at constant load  
 $t_r$  = rest time

$t_f$  = Betriebszeit mit konstanter Belastung  
 $t_r$  = Aussetzzeit

$t_f$  = temps de fonctionneent à charge constante  
 $t_r$  = temps de repos

(A7)

	SERVIZIO / DUTY / BETRIEB / SERVICE						S4 - S8 Interpellarci Please contact us Rückfrage Nous contacter
	S2			S3*			
	Durata del ciclo / Cycle duration [min] Zyklusdauer / Durée du cycle [min]			Rapporto di intermittenza / Cyclic duration factor (I) Relative Einschaltdauer / Rapport d'intermittence (I)			
$f_m$	10	30	60	25%	40%	60%	
	1.35	1.15	1.05	1.25	1.15	1.1	

\* La durata del ciclo dovrà comunque essere uguale o inferiore a 10 minuti; se superiore interpellare il Servizio Tecnico di Bonfiglioli Riduttori.

\* Cycle duration, in any event, must be 10 minutes or less. If it is longer, please contact our Technical Service.

\* Die Zyklusdauer muß in jedem Fall kleiner oder gleich 10 min sein; wenn sie darüber liegt, unseren Technisch en Kundendienst zu Rate ziehen.

\* La durée du cycle devra être égale ou inférieure à 10 minutes. Si supérieure, contacter notre Service Technique.

Nella sezione relativa alla potenza installata  $P_n$  selezionare infine il motoriduttore che sviluppa la velocità di funzionamento più prossima alla velocità  $n_2$  desiderata e per il quale il fattore di sicurezza  $S$  sia uguale, o superiore, al fattore di servizio  $f_s$ .

Next, refer to the appropriate  $P_n$  section within the gearmotor selection charts and locate the unit that features the desired output speed  $n_2$ , or closest to, along with a safety factor  $S$  that meets or exceeds the applicable service factor  $f_s$ .

Als nächstes wählen Sie anhand der Getriebemotoren auswahltabellen den Abschnitt mit der entsprechenden  $P_n$  und suchen die gewünschte Abtriebsdrehzahl  $n_2$ , oder die nächstmögliche Drehzahl, zusammen mit dem Sicherheitsfaktor  $S$ , der den zutreffenden Betriebsfaktor  $f_s$  erreicht oder überschreitet. Der Sicherheitsfaktor wird wie folgt berechnet:

Dans la section relative à la puissance installée  $P_n$  sélectionner enfin le motoréducteur qui développe la vitesse de fonctionnement la plus proche à la vitesse  $n_2$  désirée et pour lequel le facteur de sécurité  $S$  soit pareil, ou supérieur, au facteur de service  $f_s$ .

Il fattore di sicurezza è così definito:

The safety factor is so defined:

Le facteur de sécurité est défini ainsi:

$$S = \frac{Mn_2}{M_2} = \frac{Pn_1}{P_1} \quad (12)$$

Nelle tabelle di selezione motoriduttori gli abbinamenti sono sviluppati con motori a 2, 4 e 6 poli alimentati a 50 Hz. Per velocità di comando diverse da queste, effettuare la selezione con riferimento ai dati nominali forniti per i riduttori.

As standard, gear and motor combinations are implemented with 2, 4 and 6 pole motors, 50 Hz supplied. Should the drive speed be different from 2800, 1400 or 900 min-1, base the selection on the gear unit nominal rating.

Standardmäßig stehen Getriebemotorenkombinationen mit 2, 4 und 6 poligen Motoren für eine Frequenz von 50 Hz zur Verfügung. Sollten die Antriebsdrehzahlen abweichend von 2800, 1400 oder 900 min-1 sein, dann stützen Sie die Auslegung des Getriebes auf die Getriebeenddaten.

Dans les tableaux de sélection des motoréducteurs les accouplements sont développés avec moteurs à 2, 4 et 6 poles alimentés à 50 Hz. Pour vitesses de commande différentes à celles-ci, sélectionner suite aux données nominales fournies par les réducteurs.

**Scelta dei riduttori e dei riduttori predisposti per motori IEC**

**Selection of speed reducer and gearbox with IEC motor adapter**

**Wahl des Getriebes und Getriebe für IEC-motoren**

**Sélection des réducteurs et des réducteurs CEI**

- a) Determinare il fattore di servizio  $f_s$ .
- b) Conoscendo la coppia  $M_{r2}$  di uscita richiesta dalla applicazione, si procede alla definizione della coppia di calcolo:

- a) Determine service factor  $f_s$ .
- b) Assuming the required output torque for the application  $M_{r2}$  is known, the calculation torque can be then defined as:

- a) Den Betriebsfaktor  $f_s$  bestimmen.
- b) Anhand des bekannten von der Anwendung geforderten Abtriebsdrehmoments  $M_{r2}$  das Soll-Drehmoment bestimmen:

- a) Déterminer le facteur de service  $f_s$ .
- b) En connaissant le couple  $M_{r2}$  de sortie requis par l'application, l'on procède à la définition du couple de calcul:

$$M_{c2} = M_{r2} \cdot f_s \quad (13)$$



c) In base alla velocità in uscita  $n_2$  richiesta, e a quella in entrata  $n_1$  disponibile, si calcola il rapporto di riduzione:

c) *The gear ratio is calculated according to requested output speed  $n_2$  and drive speed  $n_1$ :*

c) Auf Grundlage der verlangten Abtriebsdrehzahl  $n_2$  und der verfügbaren Antriebsdrehzahl  $n_1$  die Übersetzungs berechnen:

c) *Suivant la vitesse en sortie  $n_2$  requise et celle en entrée  $n_1$  disponible, l'on calcule le rapport de réduction:*

$$i = \frac{n_1}{n_2} \quad (14)$$

Disponendo dei dati  $M_{c2}$  e  $i$ , si ricercherà nelle tabelle corrispondenti alla velocità  $n_1$  il riduttore che, in funzione del rapporto  $[i]$  più prossimo a quello calcolato, proponga una coppia nominale:

*Once values for  $M_{c2}$  and  $i$  are known consult the rating charts under the appropriate input speed  $n_1$  and locate the gear unit that features the gear ratio closest to  $[i]$  and at same time offers a rated torque value  $M_{n2}$  so that:*

Anhand der Werte für  $M_{c2}$  und  $i$  in den Tabellen für die Drehzahl  $n_1$  das Getriebe auswählen, das in Abhängigkeit von einer Übersetzung  $[i]$ , die dem Sollwert möglichst nahe ist, folgendes Nenn-Drehmoment erlaubt:

*En disposant des données  $M_{c2}$  et  $i$ , l'on recherchera dans les tableaux correspondant à la vitesse  $n_1$  le réducteur qui, en fonction du rapport  $[i]$  le plus proche de celui calculé, propose un couple nominal:*

$$M_{n2} \geq M_{c2} \quad (15)$$

Se al riduttore scelto dovrà essere applicato un motore elettrico verificarne l'applicabilità consultando la tabella delle predisposizioni possibili al paragrafo 26.

*If a IEC normalized motor must be fitted check geometrical compatibility with the gear unit at paragraph 26 - Motor availability.*

Wenn das Getriebe mit einem Elektromotor verbunden werden soll, die Verträglichkeit anhand der Tabelle der möglichen Anbaumöglichkeiten sicherstellen.

*Au cas où il serait nécessaire d'appliquer un moteur électrique normalisé au réducteur choisi, en vérifier la possible adaptation en consultant le tableau des prédispositions possibles présenté.*

## 12 - VERIFICHE

## 12 - VERIFICATION

## 12 - PRÜFUNGEN

## 12 - VERIFICATIONS

Effettuata la selezione del riduttore, o motoriduttore, è opportuno procedere alle seguenti verifiche:

*After the selection of the speed reducer, or gearmotor, is complete it is recommended that the following verifications are conducted:*

Nachdem die Auswahl des Getriebe oder Getriebemotor abgeschlossen ist, werden die folgenden Schritte empfohlen:

*Une fois effectuée la sélection du réducteur, ou motoréducteur, il faut procéder aux suivantes vérifications:*

**Se si è selezionato un riduttore fra i tipi C112, C212 e C312 con rapporto  $i > 40$ , azionato con un numero di avviamenti orari  $Z > 30$ , correggere il fattore di servizio ricavato dal grafico (A4) moltiplicandolo per 1,2.**

***For gear units type C112, C212 and C312, with ratio  $i > 40$ , operated with  $Z > 30$  switches per hour, adjust the service factor calculated through diagram (A4) and multiply the value by 1.2. Thenafter check that for the revised service factor the condition  $S \geq fs$  still applies.***

**Für Getriebeeinheiten Type C112, C212 und C312 mit Übersetzung  $i > 40$ , bei einer drehzahl von Anlaufvorgängen  $Z > 30$ , korrigiere den Servicefaktor, errechnet aus Diagramm (A4), und multipliziere den Wert mit 1,2.**

***Si un réducteur parmi les types C112, C212 et C312 a été sélectionné avec rapport  $i > 40$ , actionné avec un nombre de démarrage horaires  $Z > 30$ , corriger le facteur de service tiré du graphique (A4) en le multipliant pour 1,2. Vérifier finalement que pour la nouvelle valeur  $fs$ , la condition  $S \geq fs$  soit encore vérifiée.***

**Verificare infine nuovamente che per il nuovo valore di  $fs$  la condizione  $S \geq fs$  sia ancora verificata.**

**Danach überprüfen für den neu erhaltenen Servicefaktor, ob die Bedingung  $S \geq fs$  noch zutrifft.**

a) Potenza termica

a) *Thermal capacity*

a) *Thermische Grenzleistung*

a) *Puissance thermique*

Assicurarsi che la potenza termica del riduttore, abbia un valore uguale o maggiore alla potenza richiesta dall'applicazione secondo la relazione (3) a pag. 6, in caso contrario selezionare un riduttore di grandezza superiore oppure provvedere ad applicare un sistema di raffreddamento forzato.

*Make sure that the thermal capacity of the gearbox is equal to or greater than the power required by the application according to equation (3) on page 6. If this condition is not verified, select a larger gearbox or apply a forced cooling system.*

Sicherstellen, daß die Wärmeleistung des Getriebes größer oder gleich der verlangten Leistung ist, die von der Anwendung nach Gleichung (3) auf S. 6 verlangt wird. Andernfalls ein größer dimensioniertes Getriebe wählen bzw. ein Zwangskühlsystem vorsehen.

*S'assurer que la puissance thermique du réducteur ait une valeur supérieure ou égale à la puissance requise par l'application selon l'équation (3) page 6. Dans le cas contraire, sélectionner un réducteur de taille supérieure ou bien prévoir un système de refroidissement forcé.*



b) Coppia massima

Generalmente la coppia massima (intesa come punta di carico istantaneo) applicabile al riduttore non deve superare il 200% della coppia nominale  $M_{n2}$ ; verificare pertanto che tale limite non venga superato adottando, se necessario, opportuni dispositivi per la limitazione della coppia. Per i motori trifase a doppia polarità è necessario rivolgere particolare attenzione alla coppia di commutazione istantanea che viene generata durante la commutazione dall'alta velocità alla bassa in quanto può essere decisamente più elevata della coppia massima stessa. Un metodo semplice ed economico per ridurre tale coppia è quello di alimentare solo due fasi del motore durante la commutazione (il tempo di alimentazione a due fasi può essere regolato mediante un relè a tempo):

$M_{g2} = 0.5 \cdot M_{g3}$   
 $M_{g2}$  = Coppia di commutazione alimentando 2 fasi  
 $M_{g3}$  = Coppia di commutazione alimentando 3 fasi

Suggeriamo comunque di contattare il ns. Servizio Tecnico.

b) Maximum torque

*The maximum torque (intended as instantaneous peak load) applicable to the gearbox must not, in general, exceed 200% of rated torque  $M_{n2}$ . Therefore, check that this limit is not exceeded, using suitable torque limiting devices, if necessary. For three-phase double speed motors, it is important to pay attention to the switching torque which is generated when switching from high to low speed, because it could be significantly higher than maximum torque. A simple, economical way to minimize overloading is to power only two phases of the motor during switch-over (power-up time on two phases can be controlled with a time-relay):*

$M_{g2} = 0.5 \cdot M_{g3}$   
 $M_{g2}$  = Switching torque with two-phase power-up  
 $M_{g3}$  = Switching torque with three-phase power-up

*We recommend, in any event, to contact our Technical Service.*

b) Max. Drehmoment

Im allgemeinen darf das max. Drehmoment (verstanden als momentane Lastspitze), das auf das Getriebe aufgebracht werden kann, 200 % des Nenndrehmoments  $M_{n2}$  nicht überschreiten. Sicherstellen, daß dieser Grenzwert nicht überschritten wird, und nötigenfalls die entsprechenden Vorrichtungen zur Begrenzung des Drehmoments vorsehen. Bei polumschaltbaren Drehstrommotoren muss dem Umschaltdrehmoment, das beim Umschalten von der hohen auf die niedrige Drehzahl erzeugt wird, besondere Aufmerksamkeit geschenkt werden, da es entschieden größer sein kann als das Nenn-Drehmoment. Eine einfache und kostengünstige Methode zum Senken dieses Drehmoments besteht darin, daß nur zwei Phasen des Motors während des Umschaltens gespeist werden (die Dauer der Speisung von nur 2 Phasen kann durch ein Zeitrelais gesteuert werden):

$M_{g2} = 0.5 \cdot M_{g3}$   
 $M_{g2}$  = Umschaltdrehmoment bei Speisung von 2 Phasen;  
 $M_{g3}$  = Umschaltdrehmoment bei Speisung von 3 Phasen

Wir empfehlen jedoch in jedem Fall, unseren Technischen Kundendienst zu Rate zu ziehen.

b) Couple maximum

*Généralement, le couple maximum (à considérer comme une pointe de charge instantanée) applicable au réducteur ne doit pas dépasser les 200% du couple nominal  $M_{n2}$ . Vérifier par conséquent que cette limite ne soit pas dépassée en adoptant, si nécessaire, des dispositifs adaptés pour limiter le couple. Pour les moteurs triphasés à double polarité, il est nécessaire de prêter une attention particulière au couple de commutation instantané qui est généré lors du passage de la grande à la petite vitesse étant donné qu'il peut être considérablement plus élevé que le couple maximum lui même. Une méthode simple et économique pour réduire ce couple consiste à alimenter seulement deux phases du moteur pendant la commutation (la durée d'alimentation sur deux phases peut être réglée au moyen d'un relais temporisateur):*

$M_{g2} = 0.5 \cdot M_{g3}$   
 $M_{g2}$  = Couple de commutation en alimentant deux phases  
 $M_{g3}$  = Couple de commutation en alimentant trois phases

*Nous suggérons cependant de contacter notre Service Technique.*

c) Carichi radiali

Verificare che i carichi radiali agenti sugli alberi di entrata e/o uscita rientrino nei valori di catalogo ammessi. Se superiori, aumentare la grandezza del riduttore oppure modificare la supportazione del carico. Ricordiamo che tutti i valori indicati nel catalogo si riferiscono a carichi agenti sulla mezziera della sporgenza dell'albero in esame per cui, in fase di verifica, è indispensabile tenere conto di questa condizione provvedendo, se necessario, a determinare con le apposite formule il carico ammissibile alla distanza  $x_{1-2}$  desiderata. A tale proposito si rimanda ai paragrafi relativi ai carichi radiali.

c) Radial loads

*Make sure that radial forces applying on input and/or output shaft are within permitted catalogue values. If they were higher consider designing a different bearing arrangement before switching to a larger gear unit. Catalogue values for rated overhung loads refer to mid-point of shaft under study. Should application point of the overhung load be localised further out the revised loading capability must be adjusted as per instructions given in this manual. See paragraph 22.*

c) Radialkräfte

Sicherstellen, daß die auf die Antriebswellen und/oder Abtriebswellen wirkenden Radialkräfte innerhalb der zulässigen Katalogwerte liegen. Wenn sie höher sind, das Getriebe größer dimensionieren bzw. die Abstützung der Last verändern. Wir erinnern daran, daß alle im Katalog angegebenen Werte sich auf Kräfte beziehen, die auf die Mitte des Wellenendes wirken. Diese Tatsache muß bei der Prüfung unbedingt berücksichtigt werden und nötigenfalls muß mit Hilfe der geeigneten Formeln die zulässige Kraft beim gewünschten Abstand  $x_{1-2}$  bestimmt werden. Siehe hierzu die Erläuterungen zu den Radialkräften in diesem Katalog.

c) Charges radiales

*Vérifier que les charges radiales agissant sur les arbres d'entrée et/ou de sortie se situent dans les valeurs de catalogue admises. Si elles sont supérieures, choisir la taille du réducteur supérieure ou modifier la reprise de charge. Rappelons que toutes les valeurs indiquées dans le catalogue se réfèrent à des charges agissant au milieu de la longueur disponible de l'arbre contrôlé. Par conséquent, en phase de vérification, il est indispensable de prendre en considération cette condition en déterminant, si nécessaire, avec les formules appropriées, la charge admissible à la distance  $x_{1-2}$  désirée. Se rapporter à ce propos aux paragraphes relatifs aux charges radiales.*



- |   |  |  |   |
|---|--|--|---|
| <p>d) Carichi assiali</p> <p>Anche gli eventuali carichi assiali dovranno essere confrontati con i valori ammissibili.</p> <p>Se si è in presenza di carichi assiali molto elevati o combinati con carichi radiali, si consiglia di interpellare il ns. Servizio Tecnico.</p>                             | <p>d) Thrust loads</p> <p><i>Actual thrust load must be found within 20% of the equivalent overhung load capacity.</i></p> <p><i>Should an extremely high, or a combination of radial and axial load apply, consult Bonfiglioli Technical Service.</i></p> | <p>d) Axialkräfte</p> <p>Auch die eventuell vorhandenen Axialkräfte müssen mit den im Katalog angegebenen zulässigen Werten verglichen werden. Wenn sehr hohe Axialkräfte wirken oder Axialkräfte in Kombination mit Radialkräften, bitte unseren Technischen Kundendienst zu Rate ziehen.</p>                     | <p>d) Charges axiales</p> <p><i>Les éventuelles charges axiales devront être comparées avec les valeurs admissibles. Si l'on est en présence de charges axiales très élevées ou combinées avec des charges radiales, nous conseillons d'interpeller notre Service Technique.</i></p>  |
| <p>e) Avviamenti orari</p> <p>Per servizi diversi da S1, con un numero rilevante di inserzioni/ora si dovrà tener conto di un fattore Z (determinabile con le indicazioni riportate nel capitolo dei motori) il quale definisce il numero max. di avviamenti specifico per l'applicazione in oggetto.</p> | <p>e) Starts per hour</p> <p><i>For duties featuring a high number of switches the actual starting capability in loaded condition [Z] must be calculated.</i></p> <p><i>Actual number of starts per hour must be lower than value so calculated.</i></p>   | <p>e) Schaltungen/Stunde</p> <p>Bei anderen Betriebsarten als S1 mit einem hohen Wert für die Schaltungen/Stunde muß der Faktor Z berücksichtigt werden (er kann mit Hilfe der Angaben im Kapitel Motoren bestimmt werden), der die max. zulässige Anzahl von Schalten für eine bestimmte Anwendung definiert.</p> | <p>e) Démarrages/heure</p> <p><i>Pour les services différents de S1, avec un nombre important d'insertions/heure, il faudra prendre en considération un facteur Z (déterminé à l'aide des informations reportées dans le chapitre des moteurs) qui définit le nombre maximum de démarrages spécifique pour l'application concernée.</i></p> |

### 13 - INSTALLAZIONE

### 13 - INSTALLATION

### 13 - INSTALLATION

### 13 - INSTALLATION

È molto importante, per l'installazione del riduttore, attenersi alle seguenti norme:

*The following installation instructions must be observed:*

Für die Installation des Getriebes ist es äußerst wichtig, daß folgende Normen beachtet werden:

*Il est très important, pour l'installation du réducteur, de se conformer aux règles suivantes:*

- |   |   |  |  |
|---|---|--|--|
| <p>a) Assicurarsi che il fissaggio del riduttore, sia stabile onde evitare qualsiasi vibrazione. Installare (se si prevedono urti, sovraccarichi prolungati o possibili bloccaggi) giunti idraulici, frizioni, limitatori di coppia, ecc.</p>   | <p>a) <i>Make sure that the gearbox is correctly secured to avoid vibrations.</i></p> <p><i>If shocks or overloads are expected, install hydraulic couplings, clutches, torque limiters, etc.</i></p>   | <p>a) Sicherstellen, daß die Befestigung des Getriebes stabil ist, damit keine Schwingungen entstehen. Wenn es voraussichtlich zu Stößen, längerdauernden Überlasten oder zu Blockierungen kommen kann, sind entsprechende Schutzelemente wie hydraulische Kupplungen, Kupplungen, Rutschkupplungen usw. zu installieren.</p>  | <p>a) <i>S'assurer que la fixation du réducteur soit stable afin d'éviter toute vibration.</i></p> <p><i>Installer (en cas de chocs, de surcharges prolongées ou de blocages) des coupleurs hydrauliques, des embrayages, des limiteurs de couple etc...</i></p>   |
| <p>b) Durante la verniciatura si dovranno proteggere i piani lavorati e il bordo esterno degli anelli di tenuta per evitare che la vernice ne essichi la gomma, pregiudicando la tenuta del paraolio stesso.</p>  | <p>b) <i>Before being paint coated, the machined surfaces and the outer face of the oil seals must be protected to prevent paint drying out the rubber and jeopardising the sealing function.</i></p>   | <p>b) Beim Lackieren die bearbeiteten Flächen und die Dichtringe schützen, damit der Anstrichstoff nicht dem Kunststoff angreift und somit die Dichtigkeit der Ölabdichtungen in Frage gestellt wird.</p>  | <p>b) <i>En phase de peinture, il faudra protéger les plans usinés et le bord extérieur des bagues d'étanchéité pour éviter que la peinture ne dessèche le caoutchouc, ce qui risque de nuire à l'efficacité du joint.</i></p>   |
| <p>c) Gli organi che vanno calettati sugli alberi di uscita del riduttore devono essere lavorati con tolleranza ISO H7 per evitare accoppiamenti troppo bloccati che, in fase di montaggio potrebbero danneggiare irreparabilmente il riduttore stesso. Inoltre, per il montaggio e lo smontaggio di tali organi si consiglia l'uso di adeguati tiranti ed estrattori utilizzando il foro filettato posto in testa alle estremità degli alberi.</p> | <p>c) <i>Parts fitted on the gearbox output shaft must be machined to ISO H7 tolerance to prevent interference fits that could damage the gearbox itself. Further, to mount or remove such parts, use suitable pullers or extraction devices using the tapped hole located at the top of the shaft extension.</i></p> | <p>c) Die Organe, die mit einer Keilverbinding auf der Abtriebswelle des Getriebes befestigt werden, müssen mit einer Toleranz ISO H7 gearbeitet sein, um allzu fest blockierte Verbindungen zu vermeiden, die eventuell zu einer irreparablen Beschädigung des Getriebes während des Einbaus führen könnten. Außerdem sind beim Ein- und Ausbau dieser Organe geeignete Zugstangen und Abzieher zu verwenden, wobei die Gewindebohrung an den Köpfen der Wellen zu verwenden ist.</p> | <p>c) <i>Les organes qui sont calés sur les arbres de sortie du réducteur doivent être réalisés avec une tolérance ISO H7 pour éviter les accouplements trop serrés qui, en phase de montage, pourraient endommager irréremédiablement le réducteur. En outre, pour le montage et le démontage de ces organes, nous conseillons d'utiliser un outillage et des extracteurs appropriés en utilisant le trou taraudé situé en extrémité d'arbre.</i></p> |



- |  |  |  |   |
|--|--|--|---|
| d) Le superfici di contatto dovranno essere pulite e trattate con adeguati protettivi prima del montaggio, onde evitare l'ossidazione e il conseguente bloccaggio delle parti.   | d) <i>Mating surfaces must be cleaned and treated with suitable protective products before mounting to avoid oxidation and, as a result, seizure of parts.</i>                       | d) Die Berührungsflächen müssen sauber sein und vor der Montage mit einem geeigneten Schutzmittel behandelt werden, um Oxidierung und die daraus folgende Blockierung der Teile zu verhindern.                 | d) <i>Les surfaces de contact devront être propres et traitées avec des produits de protections appropriés avant le montage afin d'éviter l'oxydation et par suite le blocage des pièces.</i>                                   |
| e) Prima della messa in servizio del riduttore accertarsi che la macchina che lo incorpora sia in regola con le disposizioni della Direttiva Macchine 89/392 e successivi aggiornamenti.   | e) <i>Prior to putting the gear unit into operation make sure that the equipment that incorporates the same complies with the current revision of the Machines Directive 89/392.</i> | e) Bevor das Getriebe im Betrieb zu setzen, muß man sich vergewissern daß die das Getriebe einbauende Maschine gemäß den aktuellen Regelungen der Maschine Richtlinie 89/392 ist.                              | e) <i>Avant la mise en service du réducteur, vérifier que la machine où il est monté est conforme aux normes de la Directive Machines 89/392 et ses mises à jour.</i>   |
| f) Prima della messa in funzione della macchina, accertarsi che la posizione del livello del lubrificante sia conforme alla posizione di montaggio del riduttore e che la viscosità sia adeguata al tipo del carico (vedi tabella B3). | f) <i>Before starting up the machine, make sure that oil level conforms to the mounting position specified for the gear unit.</i>  | f) Vor Inbetriebnahme der Maschine sicherstellen, daß die Anordnung der Füllstandschrabe der Einbaulage angemessen ist, und die Viskosität des Schmiermittels der Belastungsart entspricht (siehe Tabelle B3). | f) <i>Avant la mise en marche de la machine, s'assurer que la position du niveau du lubrifiant soit conforme à la position de montage du réducteur et que la viscosité soit appropriée au type de charge (voir tableau B3).</i> |
| g) Nel caso di installazione all'aperto prevedere adeguate protezioni e/o carterture allo scopo di evitare l'esposizione diretta agli agenti atmosferici e alla radiazione solare.   | g) <i>For outdoor installation provide adequate guards in order to protect the drive from rainfalls as well as direct sun radiation.</i>   | g) Bei Inbetriebnahme in Frein, muß man geeigneten Schutzgeräte vorsehen, um das Antrieb gegen Regen und direkte Sonnenstrahlung zu schützen.  | g) <i>En cas d'installation en plein air, il est nécessaire d'appliquer des protections et/ou des caches appropriés de façon à éviter l'exposition directe aux agents atmosphériques et aux rayonnements solaires.</i>          |

#### 14 - STOCCAGGIO

Il corretto stoccaggio dei prodotti ricevuti richiede l'esecuzione delle seguenti attività:

- a) Escludere aree all'aperto, zone esposte alle intemperie o con eccessiva umidità.
- b) Interporre sempre tra il pavimento ed i prodotti, pianali lignei o di altra natura, atti ad impedire il diretto contatto col suolo.
- c) Per periodi di stoccaggio e soste prolungate le superfici interessate agli accoppiamenti quali flange, alberi e giunti devono essere protette con idoneo prodotto antiossidante (Mobilarma 248 o equivalente).  
In questo caso i riduttori dovranno essere posizionati con il tappo di sfiato nella posizione più alta e riempiti interamente d'olio.  
Prima della loro messa in servizio nei riduttori dovrà essere ripristinata la corretta quantità, e il tipo di lubrificante.

#### 14 - STORAGE

*Observe the following instructions to ensure correct storage of the products:*

- a) *Do not store outdoors, in areas exposed to weather or with excessive humidity.*
- b) *Always place boards, wood or other material between the products and the floor. The gearboxes should not have direct contact with the floor.*
- c) *In case of long-term storage all machined surfaces such as flanges, shafts and couplings must be coated with a suitable rust inhibiting product (Mobilarma 248 or equivalent). Furthermore gear units must be placed with the fill plug in the highest position and filled up with oil. Before putting the units into operation the appropriate quantity, and type, of oil must be restored.*

#### 14 - LAGERUNG

Die korrekte Lagerung der Antriebe erfordert folgende Vorkehrungen:

- a) Die Produkte nicht im Freien lagern und nicht in Räumen, die der Witterung ausgesetzt sind, oder eine hohe Feuchtigkeit aufweisen.
- b) Die Produkte nie direkt auf dem Boden, sondern auf Unterlagen aus Holz oder einem anderen Material lagern.
- c) Bei anhaltenden Lager- und Haltszeiten müssen die Oberflächen für die Verbindung, wie Flansche, Wellen oder Kupplungen mit einem geeigneten Oxidationsschutzmittel behandelt werden (Mobilarma 248 oder ein äquivalentes Mittel).  
Übrigens müssen die Getriebe mit nach oben gerichteter Entlüftungsschraube gelagert und mit Öl gefüllt werden.  
Die Getriebe müssen vor ihrer Verwendung mit der angegebenen Menge des vorgesehenen Schmiermittels gefüllt werden.

#### 14 - STOCKAGE

*Un correct stockage des produits reçus nécessite de respecter les règles suivantes:*

- a) *Exclude les zones à ciel ouvert, les zones exposées aux intempéries ou avec humidité excessive.*
- b) *Interposer dans tous les cas entre le plancher et les produits des planches de bois ou des supports d'autre nature empêchant le contact direct avec le sol.*
- c) *Pour une stockage de long durée il faut protéger les surfaces d'accouplement (brides, arbres, manchon d'accouplement) avec produit anti oxydant (Mobilarma 248 ou équivalent). Dans ce cas les réducteurs devront être placés avec bouchon reniflard vers le haut et complètement rempli d'huile. Avant de la mise en service du réducteur, la bon quantité d'huile devra être rétabli selon la quantité indiqué sur le catalogue.*





<b>15 - CONDIZIONI DI FORNITURA</b>	<b>15 - CONDITIONS OF SUPPLY</b>	<b>15 - LIEFERBEDINGUNGEN</b>	<b>15 - CONDITIONS DE LIVRAISON</b>
I riduttori vengono forniti come segue:	<i>Gear units are supplied as follows:</i>	Die Getriebe werden in folgendem Zustand geliefert:	<i>Les réducteurs sont livrés comme suit:</i>
a) già predisposti per essere installati nella posizione di montaggio come definito in fase di ordine;	<i>a) configured for installation in the mounting position specified when ordering;</i>	a) schon bereit für die Montage in der bei Bestellung festgelegten Einbaulage;	<i>a) déjà préparés pour être installés dans la position de montage comme défini en phase de commande;</i>
b) collaudati secondo specifiche interne;	<i>b) tested to manufacturer specifications;</i>	b) nach werksinternen Spezifikationen geprüft;	<i>b) testés selon les spécifications internes;</i>
c) le superfici di accoppiamento non sono verniciate;	<i>c) mating machined surfaces come unpainted;</i>	c) die Verbindungsflächen sind nicht lackiert;	<i>c) les surfaces de liaison ne sont pas peintes;</i>
d) provvisti di dadi e bulloni per montaggio motori per la versione IEC;	<i>d) nuts and bolts for mounting motors are provided;</i>	d) ausgestattet mit Schrauben und Muttern für die Montage der Motoren (Version mit Adapter für IEC-Motoren);	<i>d) équipés d'écrous et de boulons pour le montage des moteurs normalisés pour la version CEI;</i>
e) dotati di protezioni in plastica sugli alberi;	<i>e) shafts are protected during transportation by plastic caps;</i>	e) alle Getriebe werden mit Kunststoffschutz auf den Wellen geliefert;	<i>e) embouts de protections en plastique sur les arbres;</i>
f) provvisti di golfare di sollevamento (dove previsto).	<i>f) supplied with lifting lug (where applicable).</i>	f) mit Transporterring zum Anheben (falls vorgesehen).	<i>f) dotés d'un crochet de levage (quand cela est prévu).</i>

<b>16 - SPECIFICHE DELLA VERNICE</b>	<b>16 - PAINT SPECIFICATIONS</b>	<b>16 - ANGABEN ZU DEN ANSTRICHSTOFFE</b>	<b>16 - SPECIFICATIONS DE LA PEINTURE</b>
Le specifiche della vernice applicata sui riduttori (dove previsto) potranno essere richieste alle filiali o ai distributori che hanno fornito i gruppi.	<i>Specifications for paint applied to gearboxes (where applicable) may be obtained from the branches or dealers that supplied the units.</i>	Die Spezifikationen des Lackes, der auf den Getriebe (wo erforderlich) verwendet wurde, können bei den Filialen oder Verkaufsstellen, die die Gruppen geliefert haben, angefordert werden.	<i>Les spécification de la peinture appliquée sur les réducteurs pourront, le cas échéant, être demandées aux filiales ou aux distributeurs ayant fourni les groupes.</i>

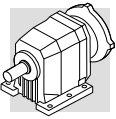

### 17 - CARATTERISTICHE COSTRUTTIVE

Le caratteristiche costruttive salienti sono:

- modularità
- compattezza
- montaggi universali
- rendimenti elevati
- basso livello di rumorosità
- ingranaggi in acciaio legato cementati e temprati
- casse in alluminio non verniciate nelle grandezze 05, 11, 21, 31, casse in ghisa ad alta resistenza, verniciate, nelle altre grandezze
- alberi in entrata e uscita in acciaio ad alta resistenza.

### 17 - DESIGN FEATURES

The main design characteristics are:

- modularity
- space effective
- universal mounting
- high efficiency
- quiet operation
- gears in hardened and case-hardened steel
- bare aluminium housing for sizes 05, 11, 21 and 31. Larger frame sizes come in sturdy cast iron housings
- input and output shafts from high grade steel.

### 17 - KONSTRUKTIVE EIGENSCHAFTEN

Die wichtigsten konstruktiven Eigenschaften sind:

- Baueinheitensystem
- Kompaktheit
- universelle Montage
- hohe Wirkungsgrade
- niedriger Geräuschpegel
- einsatzgehärtete und gehärtete Zahnräder aus legiertem Stahl
- Nicht lackierten Aluminiumgehäuse bei den Größen 05, 11, 21 und 31; hochwiderstandsfähige und lackierte Gußgehäuse bei den anderen Größen
- Antriebs- und Abtriebswellen aus hochwiderstandsfähigem Stahl.

### 17 - CARACTERISTIQUES DE CONSTRUCTION

Les principales caractéristiques de construction sont:

- modularité
- compacité
- montages universels
- rendements élevés
- faible niveau de bruit
- engrenages en acier allié cémentés et trempés
- carters en aluminium non peints dans les tailles 105, 11, 21, 31, carters en fonte à haute résistance peints dans les autres tailles
- arbres d'entrée et de sortie en acier à haute résistance.

(B1)

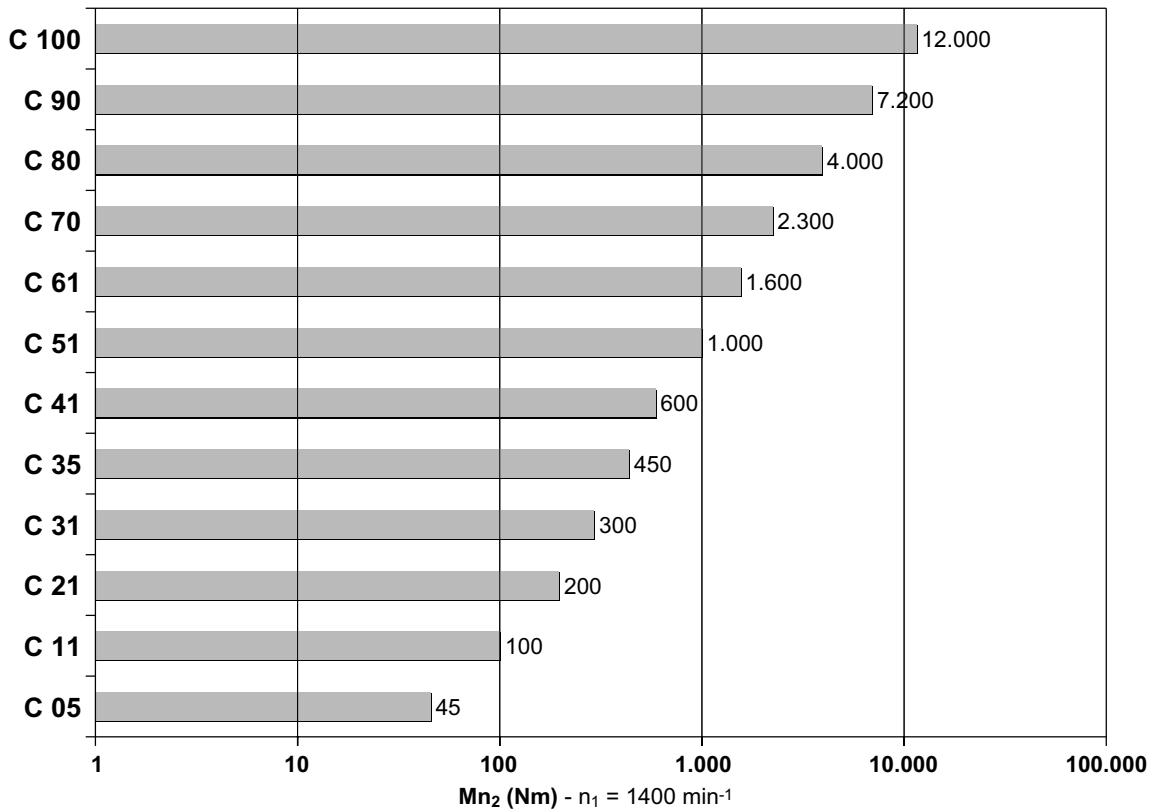

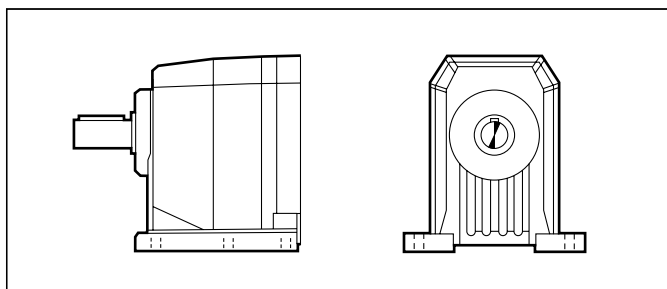
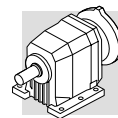
**P**

**Piedi integrali**  
*Foot mount*  
**Mit integrierten Füßen**  
*Carter à pattes monobloc*

C052...C100

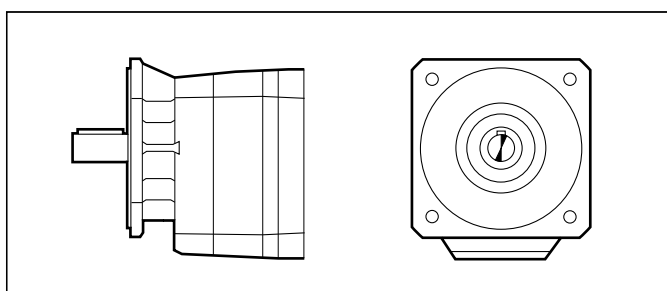
**F**

**Flangia integrale**  
*Flange mount*  
**Mit integriertem Flansch**  
*Carter à bride monobloc*

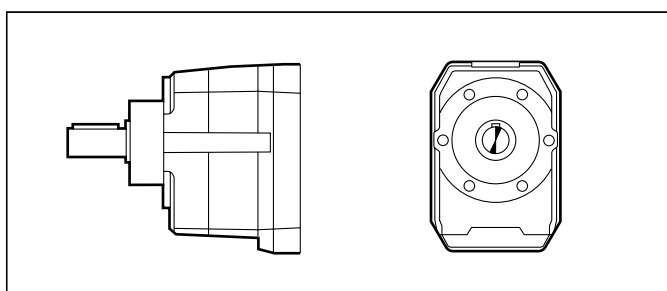
C052...C31  
C70...C100**U**

**Cassa universale UNIBOX**  
*UNIBOX- universal housing*  
**Universalgehäuse UNIBOX**  
*UNIBOX - carter universel*

C11...C61

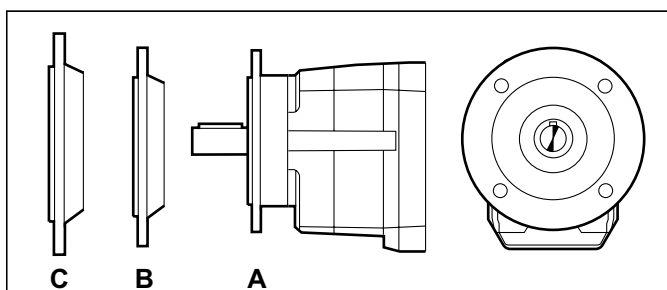
**UF**

**UNIBOX flangia riportata**  
*UNIBOX bolt-on flange*  
**UNIBOX aufgesetztem Flansch**  
*UNIBOX bride rapportée*

C11...C61

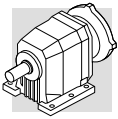

RIDUTTORE / GEAR UNIT  
GETRIEBE / REDUCTEUR

**C 31 2 F 52.4 S1 B5** .....

OPZIONI / OPTIONS  
OPTIONEN / OPTIONS



POSIZIONE DI MONTAGGIO / MOUNTING POSITION  
EINBAULAGEN / POSITION DE MONTAGE



C...P: **B3** (Standard), B6, B7, B8, V5, V6

C...F/U/UF: **B5** (Standard), B51, B53, B52, V1, V3

DESIGNAZIONE INGRESSO / INPUT CONFIGURATION  
BEZEICHNUNG DER ANTRIEBSSEITE / DESIGNATION ENTREE

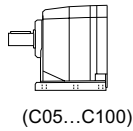

(C05...C100)

**S0**  
**S05**  
**S1**  
**S2**  
**S3**  
**S4**  
**S5**

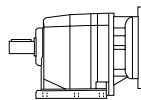
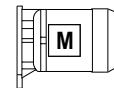

(C11...C100)

**P63**      **P160**  
**P71**      **P180**  
**P80**      **P200**  
**P90**      **P225**  
**P100**     **P250**  
**P112**     **P280**  
**P132**

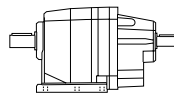
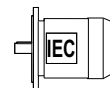

(C11...C100)

**HS**

RAPPORTO DI RIDUZIONE / GEAR RATIO  
ÜBERSETZUNG / RAPPORT DE REDUCTION

FORMA COSTRUTTIVA / VERSION / BAUFORM / FORME DE CONSTRUCTION

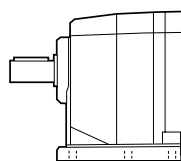

**P**  
(C05...C100)

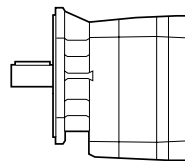

**F**  
(C05...C31)  
(C70...C100)

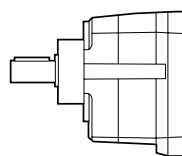

**U**  
(C11...C61)

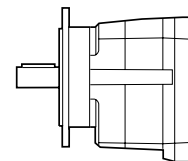

**UFA**  
**UFB**  
**UFC**  
(C11...C61)

STADI DI RIDUZIONE / REDUCTIONS  
GETRIEBESTUFEN / ETAGES DE REDUCTION

**2, 3, 4**









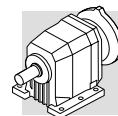







GRANDEZZA RIDUTTORE / GEAR FRAME SIZE / GETRIEBEBAUGRÖSSE / TAILLE REDUCTEUR

**05, 11, 21, 31, 35, 41, 51, 61, 70, 80, 90, 100**

TIPO RIDUTTORE: **C** = coassiale  
GETRIEBETYP: **C** = Stirnradgetriebe

GEARBOX TYPE: **C** = helical in-line  
TYPE DU REDUCTEUR: **C** = coaxial



Designazione motore	Motor designation	Motor bezeichnung	Designation moteur
	MOTORE / MOTOR MOTOR / MOTEUR	FRENO / BRAKE BREMSE / FREIN	
<b>M 1LA 4 230/400-50 IP54 CLF ..... W FD 7.5 R SB 220 SA .....</b>			
			OPZIONI OPTIONS OPTIONEN OPTIONS  22
		ALIMENTAZ. FRENO BRAKE SUPPLY BREMSVERSORGUNG ALIMENTATION FREIN	 161  166  170
		TIPO RADDRIZZATORE AC/DC RECTIFIER TYPE GLEICHRICHTERTYP TYPE ALIMENTATEUR <b>NB, SB, NBR, SBR</b>	 162
		LEVA DI SBLOCCO FRENO BRAKE HAND RELEASE BRESENTHANDLÜFTUNG LEVIER DE DEBLOCAGE FREIN <b>R, RM</b>	 173
		COPPIA FRENANTE / BRAKE TORQUE BREMSMOMENT/ COUPLE FREIN	 163  167  171
		TIPO FRENO / BRAKE TYPE BRESENTYP / TYPE DE FREIN <b>FD</b> (freno c.c./ d.c. brake / G.S. Bremse / frein c.c.) <b>FA, BA</b> (freno c.a./ a.c. brake / W.S. Bremse / frein c.a.)	 163  167  171
		POSIZIONE MORSETTIERA / TERMINAL BOX POSITION KLEMMENKASTENLAGE / POSITION BOITE A BORNE <b>W</b> (default), <b>N, E, S</b>	 25
		FORMA COSTRUTTIVA / MOTOR MOUNTING BAUFORM / FORM DE CONSTRUCTION — (motore integrato / compact motor kompaktes Motor / moteur compact) <b>B5</b> (motore IEC / IEC - motor / IEC Motor / moteur CEI)	
		CLASSE ISOLAMENTO / INSULATION CLASS ISOLIERUNGSKLASSE / CLASSE ISOLATION <b>CL F</b> standard <b>CL H</b> option	 154
		GRADO DI PROTEZIONE / DEGREE OF PROTECTION SCHUTZART / DEGRE DE PROTECTION <b>IP55</b> standard (IP54 - motore autofrenante / brake motor / Bremssmotor / moteur frein)	 148
		TENSIONE - FREQUENZA / VOLTAGE - FREQUENCY SPANNUNG - FREQUENZ / TENSION - FREQUENCE	 152
		NUMERO DI POLI / POLE NUMBER / POLZAHL / N.bre POLES <b>2, 4, 6, 2/4, 2/6, 2/8, 2/12, 4/6, 4/8</b>	
		GRANDEZZA MOTORE / MOTOR SIZE / MOTOR-BAUGRÖSSE / TAILLE MOTEUR <b>0B - 5LA</b> (motore integrato / compact motor / kompaktes Motor / moteur compact) <b>63A - 280M</b> (motore IEC / IEC motor / IEC - motor / moteur CEI)	
		TIPO MOTORE/ MOTOR TYPE / MOTORTYP / TYPE MOTEUR <b>M</b> = trifase integrato / compact 3-phase / kompaktes Dreiphasen / 3 phases compact <b>BN</b> = trifase IEC / IEC 3-phase / IEC Dreiphasen / 3 phases CEI	

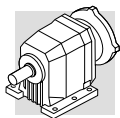

Opzioni riduttori	Gearbox options	Getriebe Optionen	Options réducteurs
<p><b>SO</b></p> <p>I riduttori C05, C11, C21, C31, C35, C41, solitamente forniti con lubrificante da BONFIGLIOLI RIDUTTORI, sono forniti privi di lubrificante.</p>	<p><b>SO</b></p> <p><i>Gear units C05, C11, C21, C31, C35, C41, usually factory filled with oil, to be supplied unlubricated.</i></p>	<p><b>SO</b></p> <p>Bei Lieferung ohne Schmierstoff (nur bei C05, C11, C21, C31, C35 und C41).</p>	<p><b>SO</b></p> <p><i>Les réducteurs C05, C11, C21, C31, C35, C41, habituellement fourni avec lubrifiant par la société BONFIGLIOLI RIDUTTORI, sont demandés sans lubrifiant.</i></p>
<p><b>LO</b></p> <p>I riduttori C51, C61, C70, C80, C90, C100 solitamente sprovvisti di lubrificante, sono richiesti con olio sintetico del tipo correntemente utilizzato da BONFIGLIOLI RIDUTTORI e riempiti in accordo alla posizione di montaggio richiesta.</p>	<p><b>LO</b></p> <p><i>Gearboxes C51, C61, C70, C80, C90, C100 usually supplied without oil, to be supplied with synthetic oil currently used by BONFIGLIOLI RIDUTTORI and filled according to the mounting position specified.</i></p>	<p><b>LO</b></p> <p>Für Getriebe C51, C61, C70, C80, C90, C100 die gewöhnlich ohne Schmiermittel geliefert werden, in Übereinstimmung mit der Einbaulage gefüllt mit dem normalerweise von BONFIGLIOLI RIDUTTORI verwendeten synthetischen Schmierstoff.</p>	<p><b>LO</b></p> <p><i>Les réducteurs C51, C61, C70, C80, C90, C100 habituellement dépourvus de lubrifiants, sont demandés avec huile synthétique du type couramment utilisé par BONFIGLIOLI RIDUTTORI et remplis conformément à la position de montage demandée.</i></p>
<p><b>DL</b></p> <p>L'albero lento è dotato di doppio anello di tenuta.</p>	<p><b>DL</b></p> <p><i>The output shaft features a dual oil seal.</i></p>	<p><b>DL</b></p> <p>Die Abtriebswelle ist mit Doppeldichtring geliefert.</p>	<p><b>DL</b></p> <p><i>L'arbre lent est équipé avec double joint d'étanchéité.</i></p>
<p><b>DV</b></p> <p>Due anelli di tenuta sull'albero veloce. (Disponibile solo sui motoriduttori compatti).</p>	<p><b>DV</b></p> <p><i>Dual oil seals on input shaft. (Only available for integral gearmotors).</i></p>	<p><b>DV</b></p> <p>2 Wellendichtringe auf der eintreibenden Welle. (Nur für Kompaktgetriebemotoren).</p>	<p><b>DV</b></p> <p><i>2 bagues d'étanchéité sur l'arbre rapide. (Disponibile seulement sur motoréducteurs compacts).</i></p>
<p><b>VV</b></p> <p>Anello di tenuta in Viton® sull'albero veloce.</p>	<p><b>VV</b></p> <p><i>Viton® oil seal on input shaft.</i></p>	<p><b>VV</b></p> <p>Wellendichtringe aus Viton® auf der eintreibenden Welle.</p>	<p><b>VV</b></p> <p><i>Bague d'étanchéité en Viton® sur l'arbre rapide.</i></p>
<p><b>PV</b></p> <p>Tutti gli anelli di tenuta in Viton®.</p>	<p><b>PV</b></p> <p><i>Both input and output shafts feature Viton® oil seals.</i></p>	<p><b>PV</b></p> <p>Alle Wellendichtringe aus Viton®.</p>	<p><b>PV</b></p> <p><i>Toutes les bagues d'étanchéité en Viton®.</i></p>

Opzioni motori	Motor options	Optionen Motoren	Options moteurs
<p><b>AA, AC, AD</b></p> <p>Posizione angolare leva di sblocco freno rispetto alla posizione morsettiera visto lato ventola. Posizione standard = 90° orari. AA = 0°, AC = 180°, AD = 90° antiorari.</p>	<p><b>AA, AC, AD</b></p> <p><i>Mutual position of the brake release lever and terminal box. View is from the fan side. Standard position = 90° clockwise.</i> AA = 0°, AC = 180°, AD = 90° counterclockwise.</p>	<p><b>AA, AC, AD</b></p> <p>geben die Lage des Bremslüfterhebels zum Klemmenkasten an. Standard ist 90° im Uhrzeigersinn beim Ansehen der Lüfterradseite. AA = 0°, AC = 180°, AD = 90° entgegen dem Uhrzeigersinn.</p>	<p><b>AA, AC, AD</b></p> <p><i>Position angulaire du levier de déblocage du frein par rapport à la position de la boîte à borne en regardant du côté du ventilateur. Position standard = 90° sens horaire.</i> AA = 0°, AC = 180°, AD = 90° sens anti-horaire.</p>
<p><b>AL, AR</b></p> <p>Antiretro (solo per motori di tipo M). Rotazione antioraria per motoriduttore a 2, 4 stadi di riduzione e oraria per motoriduttore a 3 stadi, guardando l'albero lento del motoriduttore.</p>	<p><b>AL, AR</b></p> <p><i>Anti run back (only for motors type M). CCW rotation for 2, 4 reduction stage gear motors and CW for 3 reduction stage motors viewing from gearbox output shaft.</i></p>	<p><b>AL, AR</b></p> <p>Rücklaufsperr (nur für Motoren des Typs M). Drehung entgegen dem Uhrzeigersinn für 2, 4 stufige Getriebemotoren und Drehung im Uhrzeigersinn für 3 stufige Getriebemotoren beim Anschauen der Getriebeabtriebswelle.</p>	<p><b>AL, AR</b></p> <p><i>Dispositif anti-retour (seulement pour moteurs de type M). Rotation anti-horaire pour motoréducteur à 2, 4 étages de réduction et horaire pour motoréducteur à 3 étages de réduction en regardant l'arbre lent du motoréducteur de face.</i></p>

(B2)

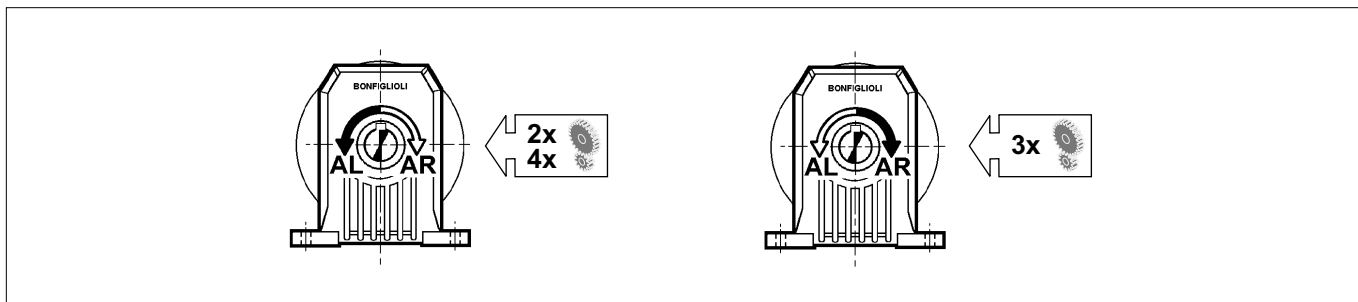

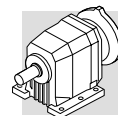

<b>CF</b> Filtro capacitivo.	<b>CF</b> <i>Capacitive filter.</i>	<b>CF</b> Kapazitive filter.	<b>CF</b> <i>Filtre capacitif.</i>
<b>D3</b> No. 3 sonde bimetalliche.	<b>D3</b> <i>3 nos bimetallic thermostats.</i>	<b>D3</b> 3 Bimetallfühler.	<b>D3</b> <i>3 sondes bimétalliques.</i>
<b>E3</b> No. 3 termistori per motori a singola polarità e doppia polarità (in accordo alla classe di isolamento).	<b>E3</b> <i>3 nos thermistors for single and double speed motors (according to the isolation class).</i>	<b>E3</b> 3 Kaltleiterthermistoren für ein-tourige Motoren und polumschaltbaren Motoren (gemäß der Isolierstoffklasse).	<b>E3</b> <i>3 thermistances pour moteurs à simple polarité ou double polarité (selon les classes d'isolation).</i>
<b>F1</b> Volano per avviamento progressivo.	<b>F1</b> <i>Flywheel for soft start and stop.</i>	<b>F1</b> Schwungrad zum sanften Anfahren.	<b>F1</b> <i>Volant pour démarrage progressif.</i>
<b>H1</b> Riscaldatori anticondensa. Alimentazione standard 230V±10%.	<b>H1</b> <i>Anti condensate heaters. Standard voltage 230V±10%.</i>	<b>H1</b> Wicklungsheizung Standardspannung 230 V±10%	<b>H1</b> <i>Réchauffeurs anticondensation. Alimentation standard 230V±10%.</i>
<b>PN</b> Potenza a 60 Hz corrispondente alla potenza normalizzata a 50 Hz.	<b>PN</b> <i>60 Hz power corresponding to the normalized 50 Hz power.</i>	<b>PN</b> Die 60 Hz-Leistung wird an der 50 Hz-Normleistung ausgeglichen.	<b>PN</b> <i>Puissance à 60 Hz correspondante à la puissance normalisée à 50 Hz.</i>
<b>PS</b> Doppia estremità d'albero (esclude opzione RC e U1).	<b>PS</b> <i>Double shaft extention (barring RC and U1 options).</i>	<b>PS</b> Zweites Wellenende (schließt die Optionen RC und U1 aus).	<b>PS</b> <i>Double extrémité d'arbre (à l'exclusion de l'option RC et U1).</i>
<b>RC</b> Tettuccio parapioggia (esclude opzione PS).	<b>RC</b> <i>Drip cover (barring option PS).</i>	<b>RC</b> Schutzdach (schließt Option PS aus).	<b>RC</b> <i>Capot protection antipluie (option PS exclue).</i>
<b>RV</b> Bilanciamento rotore in grado di vibrazione R.	<b>RV</b> <i>Rotor balancing in vibration class R.</i>	<b>RV</b> Läufer in Vibrationsgrad R ausgewuchtet.	<b>RV</b> <i>Equilibrage rotor avec degré de vibration R.</i>
<b>TC</b> La variante del tettuccio tipo TC è da specificare quando il motore è installato in ambienti dell'industria tessile. L'opzione esclude le varianti EN1, EN2, EN3 e non è applicabile ai motori con freno tipo BA.	<b>TC</b> <i>Option TC is a rain canopy variant for textile industry environments. This option is not compatible with variants EN1, EN2, EN3 and will not fit motors equipped with a BA brake.</i>	<b>TC</b> Bei dieser Option handelt es sich um ein Schutzdachs mit einem Textilnetz, dessen Einsatz empfohlen wird wenn der Motor in Bereichen der Textilindustrie installiert wird. Diese Option schließt die Möglichkeit der Optionen EN1, EN2, EN3 aus und kann bei Bremsmotoren vom Typ BN_BA nicht montiert werden.	<b>TC</b> <i>La variante du capot type TC est à spécifier lorsque le moteur est installé dans des sites de l'industrie textile. L'option exclue les variantes EN1, EN2, EN3 et n'est pas applicable aux moteurs avec frein type BA.</i>
<b>TP</b> Tropicalizzazione.	<b>TP</b> <i>Tropicalization.</i>	<b>TP</b> Tropfenfestigkeit.	<b>TP</b> <i>Tropicalisation.</i>
<b>U1</b> Servoventilazione (esclude opzioni PS e CUS).	<b>U1</b> <i>Forced cooling (barring options PS and CUS).</i>	<b>U1</b> Fremdbelüftung (Nicht anwendbare Gesamtheit an den Optionen PS und CUS).	<b>U1</b> <i>Servo-ventilateur (Pas applicable ensemble aux options PS et CUS).</i>
<b>U2</b> Servoventilatore privo di scatola morsettiera, dotato di cavi pre-cablati internamente. Esclude le opzioni PS e CUS.. Disponibile per motori: BN 71 ... BN 132, M1 ... M4.	<b>U2</b> <i>Separate supply forced ventilation without terminal box. Cables are pre-wired. Configuration is not compatible with options PS and CUS. Available on motors; BN 71 ... BN 132, M1 ... M4.</i>	<b>U2</b> Servoventilator ohne Klemmenkasten, bereits intern verkabelt. Nicht anwendbare Gesamtheit an den Optionen PS und CUS. Verfügbar für folgende Motoren: BN 71 ... BN 132, M1 ... M4.	<b>U2</b> <i>Servoventilateur sans boîte à bornes, doté de câbles pré-cablés à l'intérieur. Pas applicable ensemble aux options PS et CUS. Disponible pour moteurs: BN 71 ... BN 132, M1 ... M4.</i>

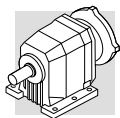

## 20 - LUBRIFICAZIONE

Gli organi interni dei riduttori Bonfiglioli sono lubrificati con un sistema misto di immersione e sbattimento dell'olio.

I gruppi C05, C11, C21, C31, C35 e C41 sono normalmente consegnati con carica di lubrificante dalla fabbrica, o dalla rete di vendita ufficiale.

Per questi stessi gruppi, nell'esecuzione predisposta per motorizzazione normalizzata IEC, un tappo di sfianto è fornito a corredo e dovrà essere installato ad esclusione della posizione di montaggio V5, prima della messa in esercizio del riduttore.

I gruppi di grandezza C51 e superiori sono normalmente forniti privi di lubrificante, e sarà cura dell'utilizzatore riempirli di olio prima della messa in servizio.

Le tavole che seguono sono da riferimento nell'interpretazione delle posizioni di montaggio, della collocazione dei tappi di servizio e delle quantità di lubrificante.

**Queste ultime sono indicative, e per il corretto riempimento si dovrà fare riferimento alla mezzeria del tappo, o dell'astina di livello, se presente.**

**Rispetto a questa condizione la quantità di lubrificante riportata in tabella può presentare scostamenti, occasionalmente anche rilevanti.**

Il lubrificante "long life" fornito di serie è di natura sintetica e, a meno di contaminazione dall'esterno, non richiede sostituzioni periodiche per tutto l'arco di vita del riduttore.

Lo stesso lubrificante consente inoltre funzionamenti a temperatura ambiente  $0 < t_a < 50\text{ °C}$ .

Per funzionamento a temperature inferiori consultare il ns. Servizio Tecnico.

## 20 - LUBRICATION

*The inner parts of Bonfiglioli gear units are oil-bath and splash lubricated.*

*Frame sizes C05, C11, C21, C31, C35 and C41 are supplied by the factory, or by the authorized dealers, already filled with oil.*

*For same units configured with the IEC-normalized motor mounting flange a breather plug is also supplied. With the exception of the V5 mounting position, the breather must replace the closed plug supplied for transportation purposes, prior to putting the gear unit into operation.*

*Unless otherwise specified, units size C51 and larger are usually supplied unlubricated at it will be the customer care to fill them with oil prior to putting them into operation.*

*The charts here after must be referred to as for the mounting position pattern and the corresponding oil plugs, if applicable, and related lubricant quantity.*

*Values for the oil quantity are indicative with the proper filling always represented by the center of the sight glass, or the dipstick, when this is supplied.*

*In some cases, discrepancies, occasionally also substantial, versus the oil quantities listed in the chart may be noticed.*

*The "long life" polyglycol-based lubricant supplied by the factory, in the absence of contamination, does not require periodical oil changes throughout the lifetime of the gear unit.*

*Operation at an ambient temperature  $0 < t_a < 50\text{ °C}$  is allowed.*

*Should the gear unit operate at temperature below  $0\text{ °C}$ , please consult Bonfiglioli Technical Service Dept. for advise.*

## 20 - SCHMIERUNG

Die Schmierung der Getriebe von Bonfiglioli erfolgt durch eine Kombination aus Ölbad- und Tauchschmierung.

Die Getriebegrößen C05, C11, C21, C31, C35 und C41 sind ab Werk mit einer Lebensdauer-schmierung versehen.

Wenn diese Baugrößen mit einem IEC-Eingang ausgeliefert werden, dann gehört ein Lüfter zum Lieferumfang, außer bei der Einbaulage V5. Während des Transports wird anstatt des Lüfters ein Stopfen verwendet. Vor dem Einsatz des Getriebes muss dieser Stopfen durch den Lüfter ersetzt werden.

Die Getriebe ab der Größe C51 werden ohne Ölfüllung ausgeliefert. Vor der Inbetriebnahme muss deshalb auf das Einfüllen der richtigen Ölfüllmenge geachtet werden!

Bitte beachten Sie dazu auch die nachfolgenden Kapitel über die Positionen der Stopfen und Ölschaugläser und den entsprechenden Ölfüllmengen.

**Die im Katalog angegebenen Ölfüllmengen sind Anhaltswerte! Maßgebend ist, das der Ölstand bis Mitte des Ölschauglas für die entsprechende Einbaulage aufgefüllt wird.**

**Auf Abweichungen gegenüber den in der Tabelle angegebenen Ölmengen, gelegentlich nicht unwesentliche, wird hingewiesen.**

Die mit Lebensdauerschmierung gelieferten Serien sind mit synthetischem Öl auf Polyglykolbasis gefüllt. Falls dieses Öl nicht verunreinigt wird, ist während der Lebensdauer des Getriebes kein Ölwechsel nötig.

Die zulässige Umgebungstemperatur für den Betriebe liegt im Bereich von  $0 < t_a < 50\text{ °C}$ .

Falls ein Antrieb bei Temperaturen unterhalb von  $0\text{ °C}$  betrieben werden soll, kontaktieren sie bitte unseren technischen Service für weitere Anweisungen.

## 20 - LUBRIFICATION

*Les organes internes des réducteurs Bonfiglioli sont lubrifiés avec un système mixte d'immersion et de battement de l'huile.*

*Les groupes C05, C11, C21, C31, C35 et C41 sont normalement livré avec charge de lubrifiant de l'usine, ou du réseau de vente officielle.*

*Pour ces mêmes groupes, dans l'exécution prévue pour motorisation normalisée IEC, un bouchon de reniflard est fourni et devra être installé, sauf position de montage V5, avant la mise en service du réducteur.*

*Les groupes de grandeur C51 et supérieur sont normalement fournis sans lubrifiant, et sera par l'utilisateur le remplissage d'huile avant la mise en service.*

*Les tables suivantes sont de référence dans l'interprétation des positions de montage, du placement des bouchons de service et de la quantité de lubrifiant.*

**Ces dernières sont indicatives, et pour le correct remplissage il faut faire référence au bouchon de niveau ou à la jauge à huile, si présent.**

**Par rapport à cette condition la quantité de lubrifiant indiquée dans le tableau peut présenter des écartement, occasionnellement considérables.**

*Le lubrifiant "long life" ; fourni de série est de nature synthétique et, à moins de contamination par l'extérieur, il ne demande pas des remplacements périodiques pour tout l'arc de vie du réducteur.*

*Le même lubrifiant permet fonctionnements à des températures ambiant  $0 < t_a < 50\text{ °C}$ .*

*Pour fonctionnement à des températures inférieures consulter notre Service Technique.*

(B3)

Tipo di carico / Type of duty Art der Belastung / Type de charge	ta 0 °C - 20 °C		ta 20 °C - 40 °C	
	Olio minerale Mineral oil Mineralöl Huile minérale ISO VG	Olio sintetico Synthetic oil Syntheseöl Huile synthétique ISO VG	Olio minerale Mineral oil Mineralöl Huile minérale ISO VG	Olio sintetico Synthetic oil Syntheseöl Huile synthétique ISO VG
Carico leggero / Light duty / Leicht / Charge légère	150	150	220	220
Carico medio / Medium duty / Normal / Charge moyenne	150	150	320	220
Carico pesante / Heavy duty / Schwer / Charge lourde	200	200	460	320



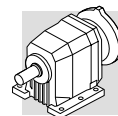



Quantità di lubrificante [ l ]

Oil quantity [ l ]

Schmiermittelmenge [ l ]

Quantité de lubrifiant [ l ]

(B4)

	 [ l ]																	
	P						F						U - UF					
	B3	B6	B7	B8	V5	V6	B5	B51	B53	B52	V1	V3	B5	B51	B53	B52	V1	V3
C 05 2	0.35	0.35	0.35	0.35	0.35	0.35	0.35	0.35	0.35	0.35	0.35	0.35	-	-	-	-	-	-
C 11 2	0.45	0.45	0.45	0.45	0.50	0.60	0.40	0.40	0.50	0.50	0.50	0.60	0.40	0.40	0.50	0.50	0.50	0.60
C 21 2	0.80	0.80	0.80	0.80	0.85	1.1	0.75	0.75	0.75	0.75	0.80	1.00	0.75	0.75	0.75	0.75	0.80	1.00
C 21 3	1.2	1.2	1.2	1.2	1.3	1.4	1.2	1.2	1.2	1.2	1.3	1.4	1.2	1.2	1.2	1.2	1.3	1.4
C 31 2	1.4	1.4	1.4	1.4	1.5	1.5	1.3	1.3	1.3	1.3	1.5	1.5	1.3	1.3	1.3	1.3	1.5	1.5
C 31 3	1.6	1.6	1.6	1.6	1.8	1.8	1.6	1.6	1.6	1.6	1.8	1.8	1.6	1.6	1.6	1.6	1.8	1.8
C 35 2	1.6	1.5	1.5	1.3	2.1	2.4	-	-	-	-	-	-	1.6	1.5	1.5	1.3	2.1	2.4
C 35 3	1.5	1.4	1.5	1.3	2.0	2.3	-	-	-	-	-	-	1.5	1.4	1.5	1.3	2.0	2.3
C 35 4	2.3	2.1	2.3	2.1	2.7	3.1	-	-	-	-	-	-	2.3	2.1	2.3	2.1	2.7	3.1
C 41 2	2.2	2.0	2.1	1.9	2.7	3.4	-	-	-	-	-	-	2.2	2.0	2.1	1.9	2.7	3.4
C 41 3	2.1	1.9	2.1	1.9	2.6	3.2	-	-	-	-	-	-	2.1	1.9	2.1	1.9	2.6	3.2
C 41 4	2.8	2.6	2.8	2.6	3.5	3.9	-	-	-	-	-	-	2.8	2.6	2.8	2.6	3.5	3.9
C 51 2	3.1	3.0	3.1	3.0	4.3	5.0	-	-	-	-	-	-	3.1	3.0	3.1	3.0	4.3	5.0
C 51 3	3.0	2.8	3.1	3.0	4.1	4.9	-	-	-	-	-	-	3.0	2.8	3.1	3.0	4.1	4.9
C 51 4	4.3	4.1	4.4	4.2	5.4	6.1	-	-	-	-	-	-	4.3	4.1	4.4	4.2	5.4	6.1
C 61 2	4.2	4.0	4.2	4.1	6.0	6.7	-	-	-	-	-	-	4.2	4.0	4.2	4.1	6.0	6.7
C 61 3	4.2	4.0	4.2	4.1	6.0	6.7	-	-	-	-	-	-	4.2	4.0	4.2	4.1	6.0	6.7
C 61 4	6.1	5.9	6.1	6.0	7.9	8.6	-	-	-	-	-	-	6.1	5.9	6.1	6.0	7.9	8.6
C 70 2	6.5	8.5	8.5	7.5	11	7.5	6.5	8.5	8.5	7.5	11	7.5	-	-	-	-	-	-
C 70 3	6.5	8.5	8.5	7.5	11	7.5	6.5	8.5	8.5	7.5	11	7.5	-	-	-	-	-	-
C 70 4	6.5	8.5	8.5	7.5	11	8	6.5	8.5	8.5	7.5	11	7.5	-	-	-	-	-	-
C 80 2	11	14	14	13	18	13	11	14	14	13	18	13	-	-	-	-	-	-
C 80 3	11	14	14	13	18	13	11	14	14	13	18	13	-	-	-	-	-	-
C 80 4	11	14	14	13	18	13	11	14	14	13	18	13	-	-	-	-	-	-
C 90 2	19	25	25	22	31	22	19	25	25	22	31	22	-	-	-	-	-	-
C 90 3	19	25	25	22	31	22	19	25	25	22	31	22	-	-	-	-	-	-
C 90 4	19	25	25	22	31	22	19	25	25	22	31	22	-	-	-	-	-	-
C 100 2	27	37	37	33	45	33	27	37	37	33	45	33	-	-	-	-	-	-
C 100 3	27	37	37	33	45	33	27	37	37	33	45	33	-	-	-	-	-	-
C 100 4	27	37	37	33	45	33	27	37	37	33	45	33	-	-	-	-	-	-

 Lubrificazione permanente

 Life lubricated

 Dauerschmierung

 Lubrification permanente

 SHELL Tivela OIL S 320 (for life)

## 21- POSIZIONI DI MONTAGGIO E ORIENTAMENTO MORSETTIERA

Gli orientamenti delle morsettiere dei motori sono identificati osservando il motore dal lato ventola; l'orientamento standard è evidenziato in nero (W).

### Posizione angolare leva di sblocco freno.

Nei motori autofrenanti, la leva di sblocco freno (se richiesta) ha l'orientamento standard a 90° rispetto alla morsettiere (posizione AB); specificare con relative opzioni qualora l'orientamento desiderato sia diverso.

## 21 - MOUNTING POSITION AND TERMINAL BOX ORIENTATION

Location of motor terminal box can be specified by viewing the motor from the fan side; standard location is shown in black (W).

### Angular position of the brake release lever.

Unless otherwise specified, brake motors have the manual device side located, 90° apart from terminal box. Different angles can be specified through the relevant options available.

## 21 - EINBAULAGEN UND LAGE DES KLEMMKASTENS

Die Angaben zur Lage des Klemmkastens beziehen sich auf das von der Lüfterseite her betrachtete Getriebe. Die Standardorientierung ist schwarz hervorgehoben (W).

### Winkellage des Handlüfterhebels.

Bei Bremsmotoren wird der Handlüfterhebel (auf Anfrage) standardmäßig auf 90° gegenüber des Klemmkastens (AB-Anordnung) geliefert; wird eine andere Anordnung verlangt, muß dies bei der Bestellung durch das geeignete Option angegeben werden.

## 21 - POSITIONS DE MONTAGE ET ORIENTATION BOITE A BORNE

Les orientations des boîtes à bornes des moteurs sont définies en regardant le moteur du côté ventilateur. L'orientation standard est indiquée en noir (W).

### Position angulaire levier déblocage frein.

Dans les moteurs freins, ce levier (si requis) aura l'orientation standard de 90° par rapport à la boîte à bornes (position AB); spécifier avec options relatives si l'orientation désirée est différente.

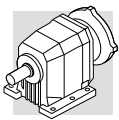

# C 11...C41

Legenda:	Key:	Zeichenerklärung:	Légende:	
	Tappo di sfiato / carico	Filling / breather plug	Einfüll / Ablasschraube	<i>Bouchon de event / remplissage</i>
	Tappo di livello	Level plug	Östandsschraube	<i>Bouchon de niveau</i>
	Tappo di scarico	Drain plug	Öablasschraube	<i>Bouchon de vidange</i>

## C\_P

(B5)

### B3

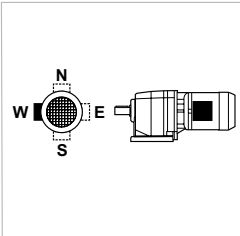
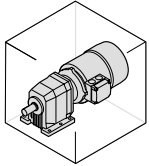

W = Default

### \_HS

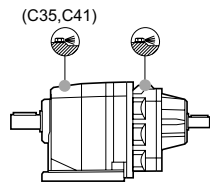
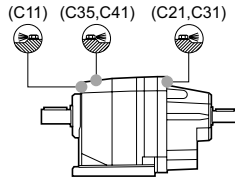

### \_P (IEC)

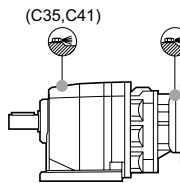
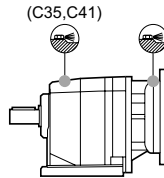

### \_S

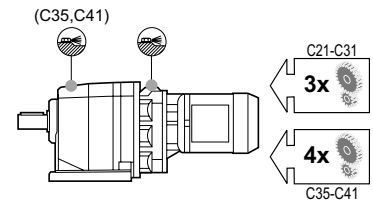
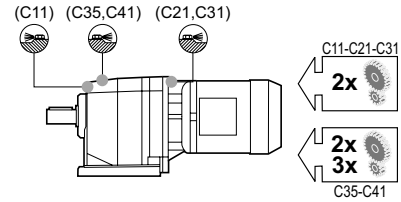

### B6

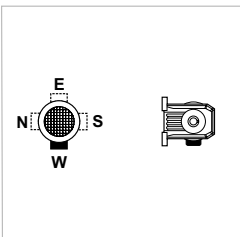
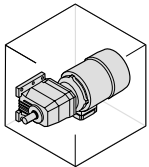

W = Default

(C35,C41)

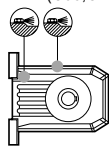

(C35,C41)

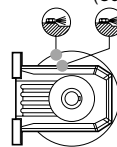

(C35,C41)

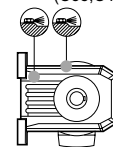

(C35,C41)

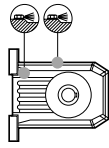

(C35,C41)

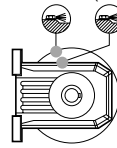

(C35,C41)

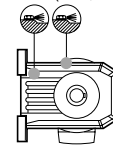

### B7

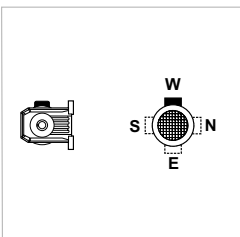
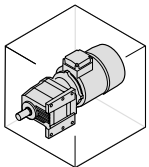

W = Default

(C11) (C35,C41)

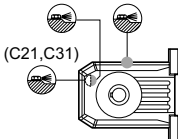

(C35,C41)

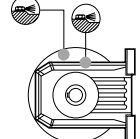

(C11) (C35,C41)

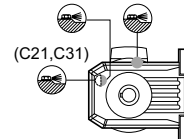

(C35,C41)

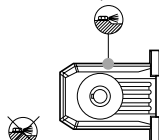

(C35,C41)

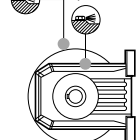

(C35,C41)

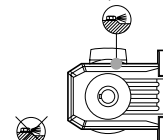

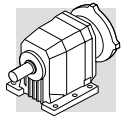

## C\_P

(B6)

**\_HS**

**\_P (IEC)**

**\_S**

**B8**

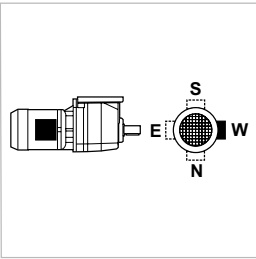
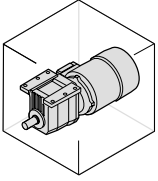

W = Default

(C21,C31) (C11,C35,C41)

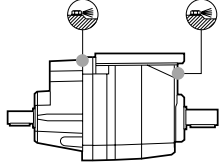

(C35,C41)

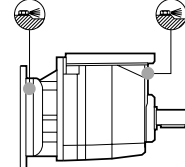

(C35,C41)

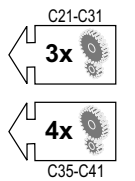
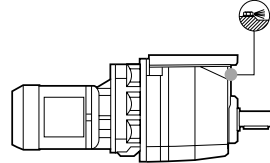
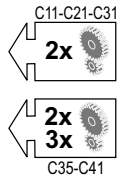
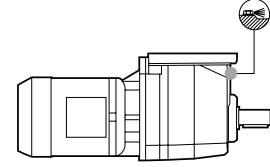
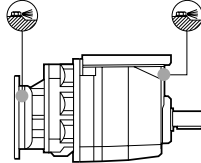

**V5**

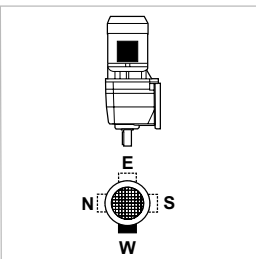
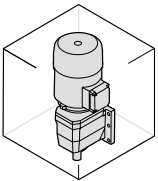

W = Default

(C21, C31, C35, C41)

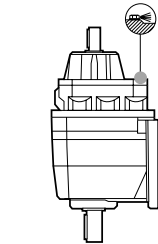
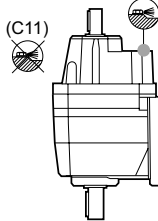

(C35, C41)

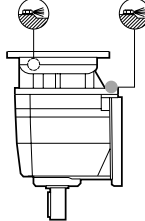

(C35, C41)

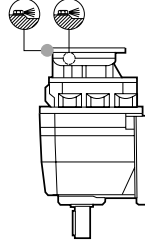

(C21, C31)

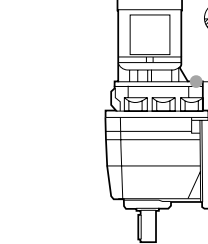
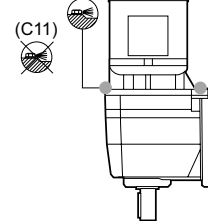

(C35, C41)

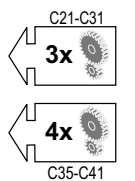
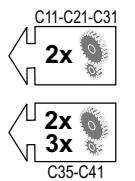
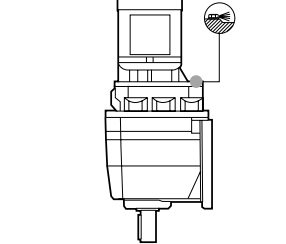
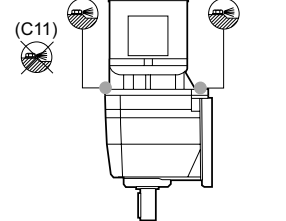

**V6**

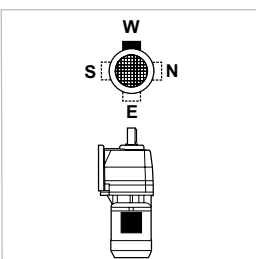
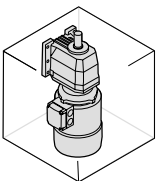

W = Default

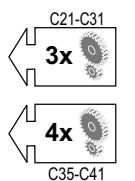
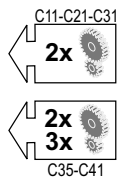
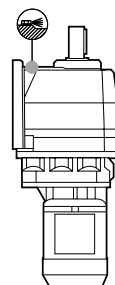
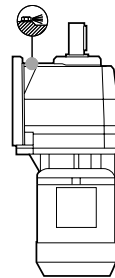
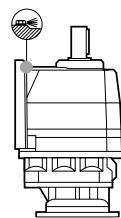
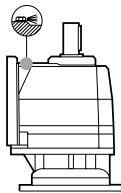
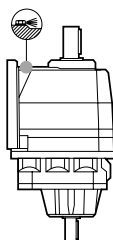
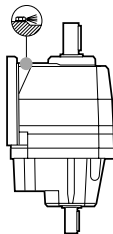

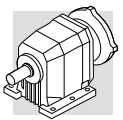

# C 11...C 41

C\_F

C\_U

C\_UF

(B7)

\_HS

\_P (IEC)

\_S

B5

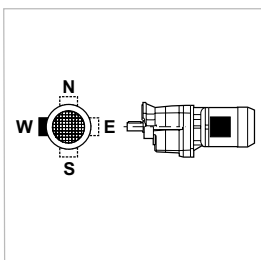
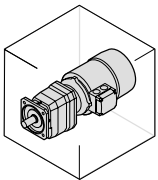

W = Default

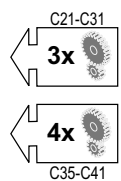
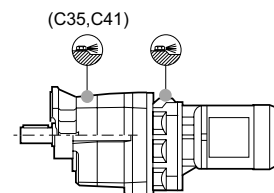
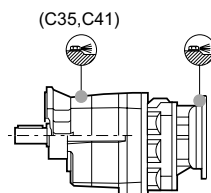
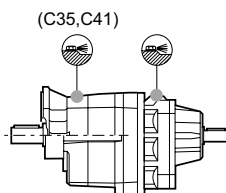
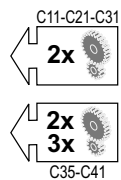
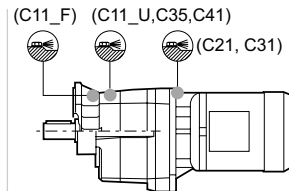
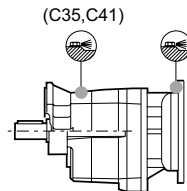
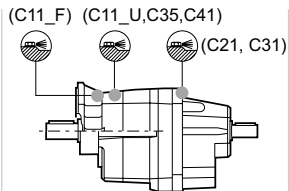

B51

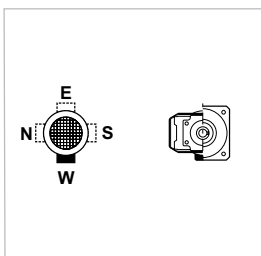
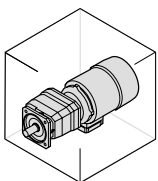

W = Default

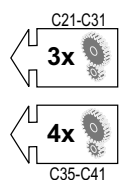
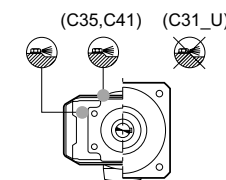
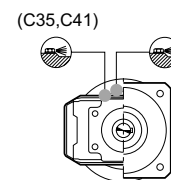
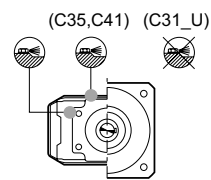
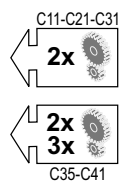
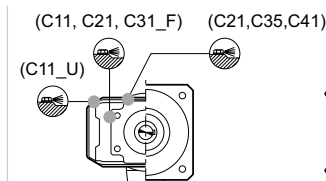
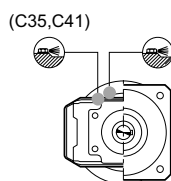
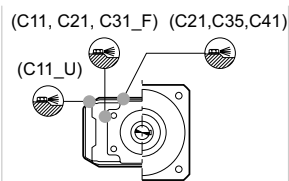

B53

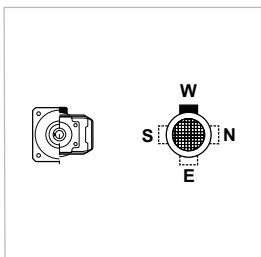
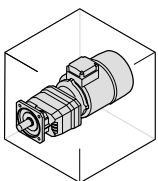

W = Default

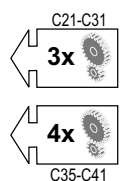
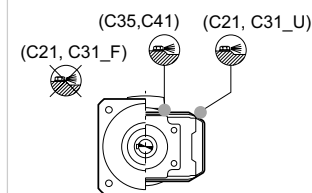
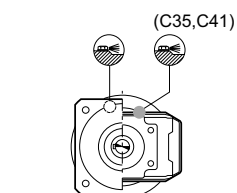
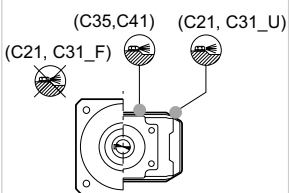
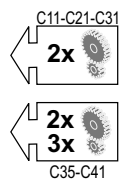
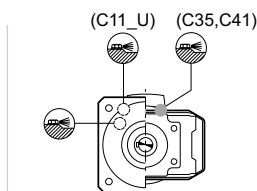
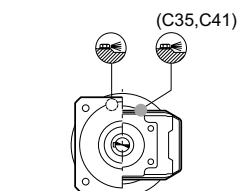
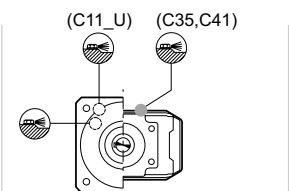

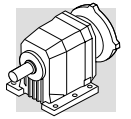

<b>C_F</b>	<b>C_U</b>	<b>C_UF</b>
------------	------------	-------------

(B8)

**\_HS**

**\_P (IEC)**

**\_S**

**B52**

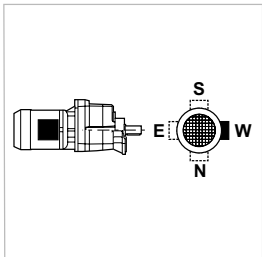
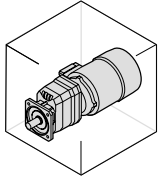

W = Default

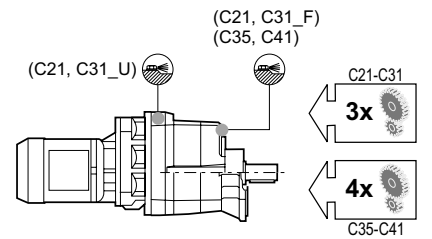
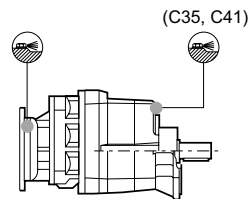
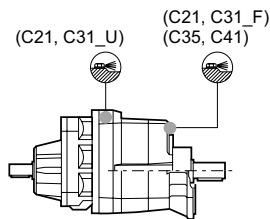
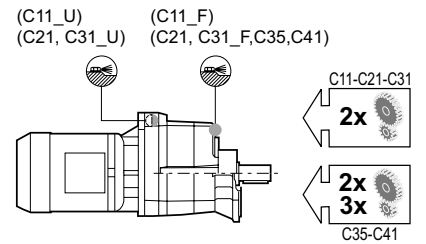
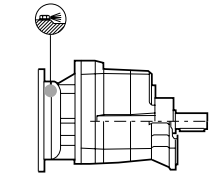
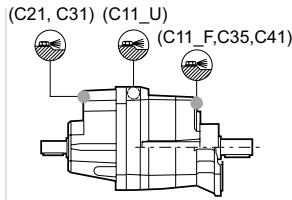

**V1**

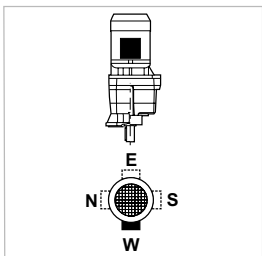
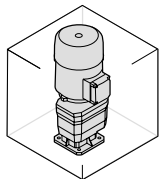

W = Default

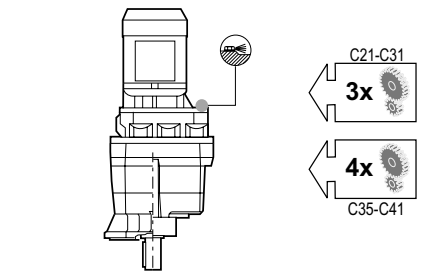
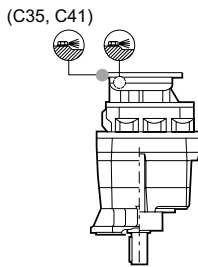
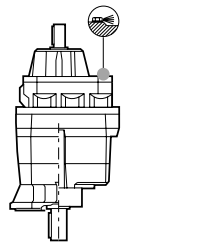
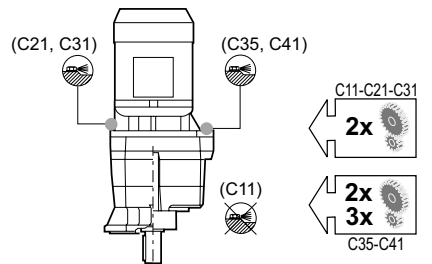
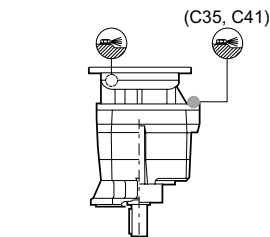
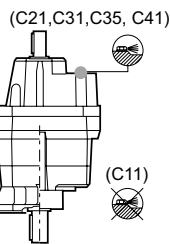

**V3**

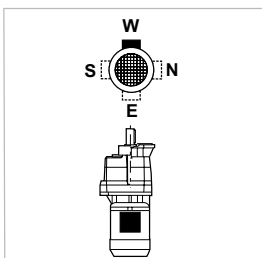
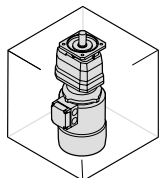

W = Default

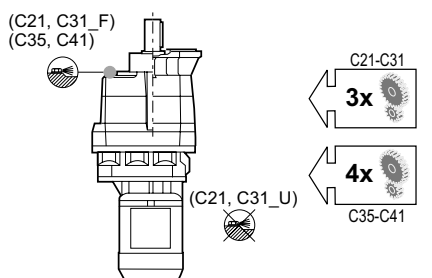
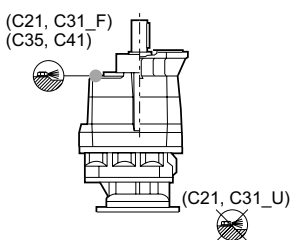
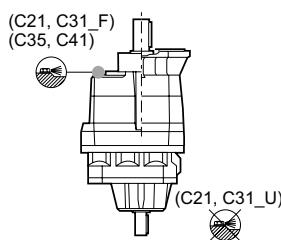
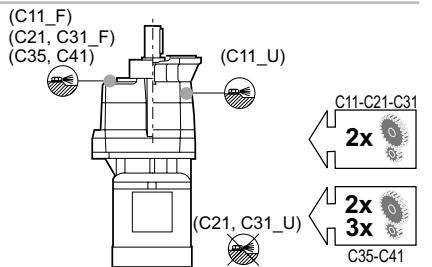
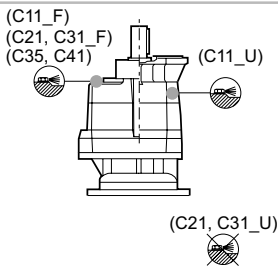
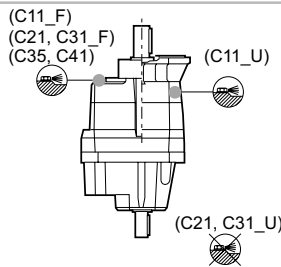

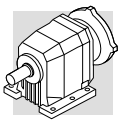

# C 51...C 61

## C\_P

(B9)

**\_HS**

**\_P (IEC)**

**\_S**

**B3**

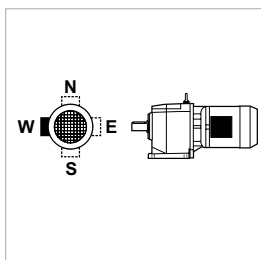
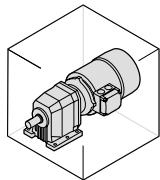

W = Default

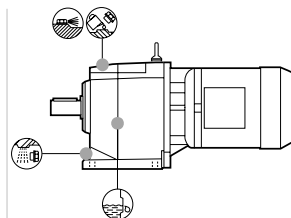
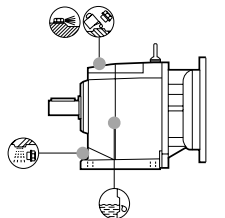
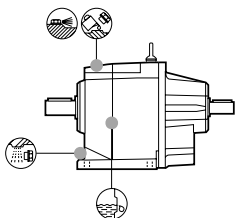

2x  
3x

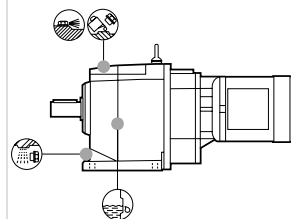
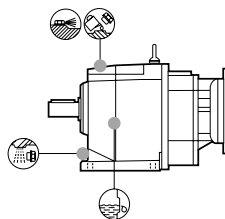
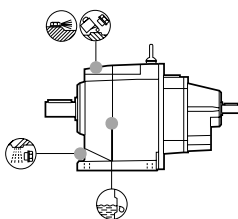

4x

**B6**

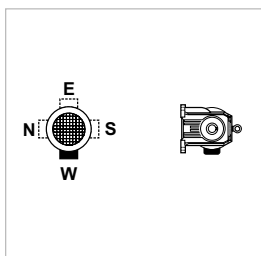
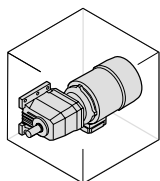

W = Default

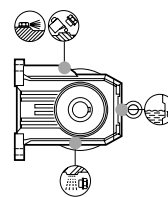
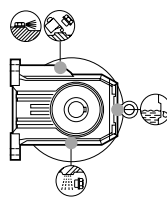
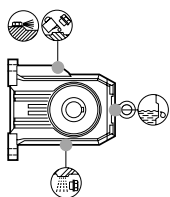

2x  
3x

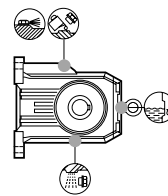
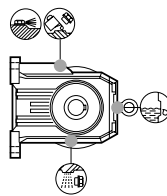
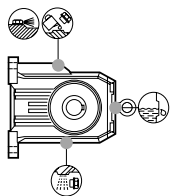

4x

**B7**

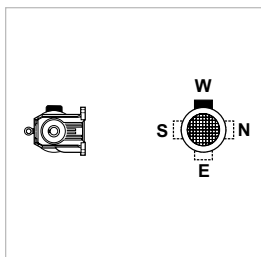
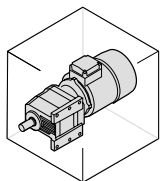

W = Default

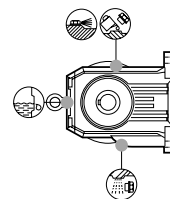
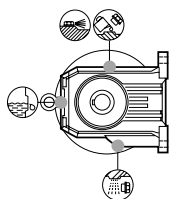
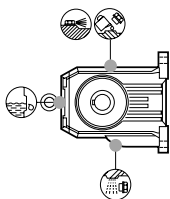

2x  
3x

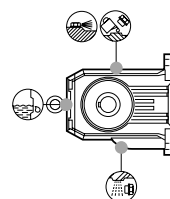
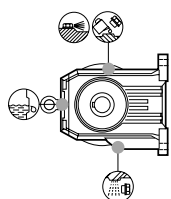
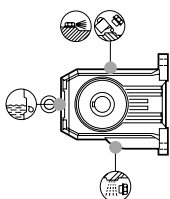

4x

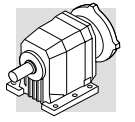

## C\_P

(B10)

**\_HS**

**\_P (IEC)**

**\_S**

**B8**

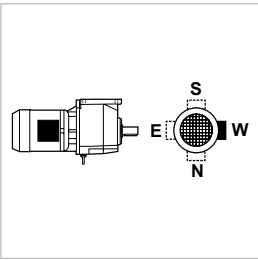
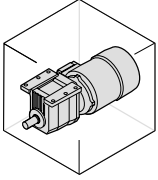

W = Default

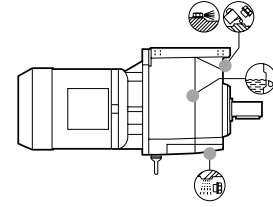
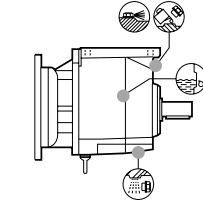
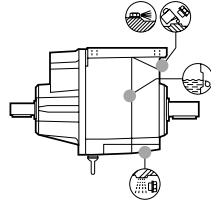

2x  
3x

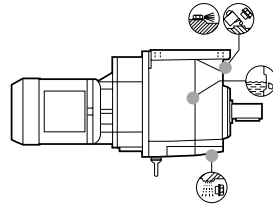
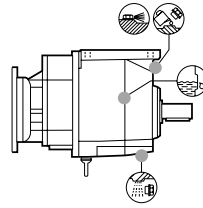
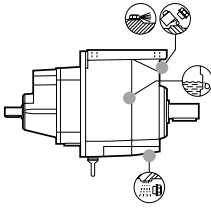

4x

**V5**

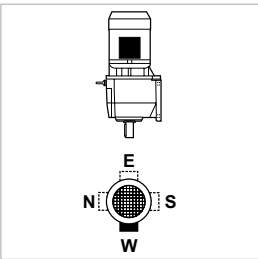
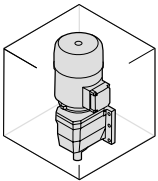

W = Default

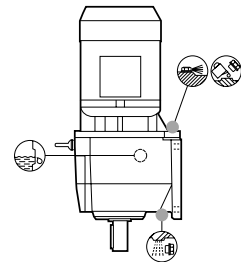
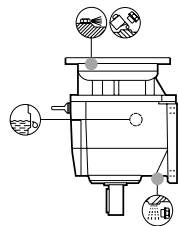
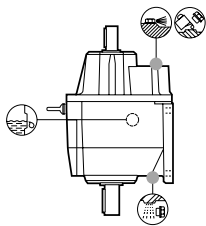

2x  
3x

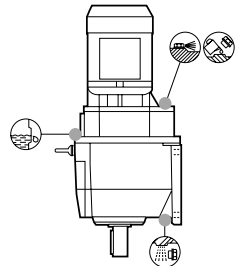
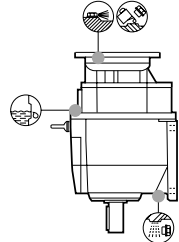
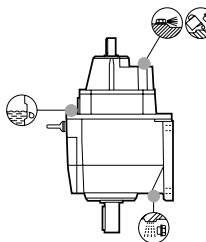

4x

**V6**

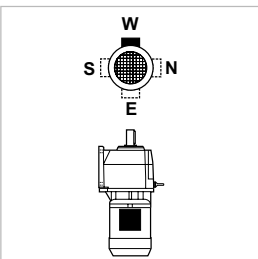
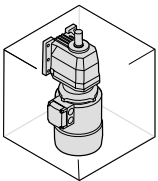

W = Default

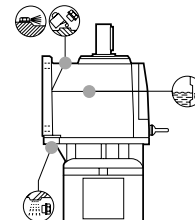
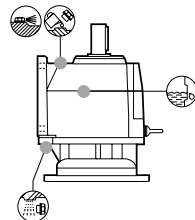
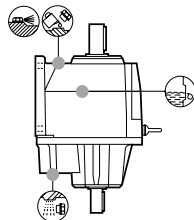

2x  
3x

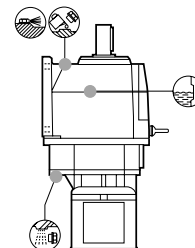
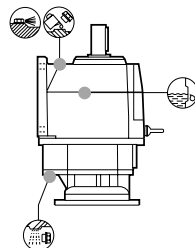
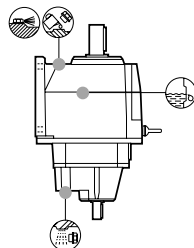

4x

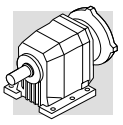

# C 51...C 61

C\_F

C\_U

C\_UF

(B11)

\_HS

\_P (IEC)

\_S

B5

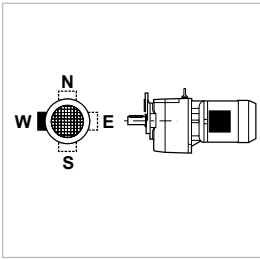
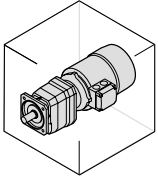

W = Default

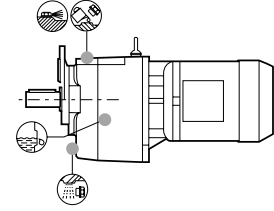
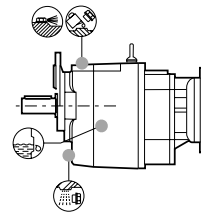
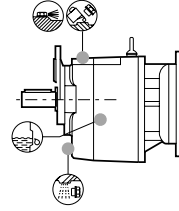
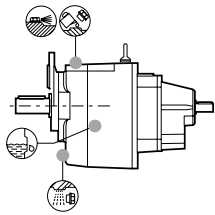
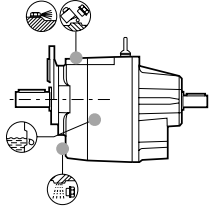

2x  
3x

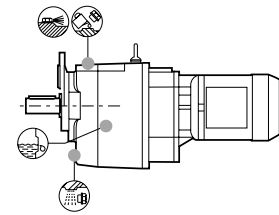

4x

B51

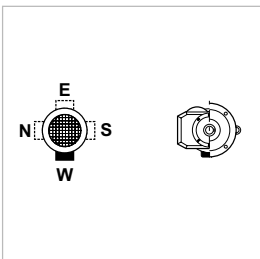
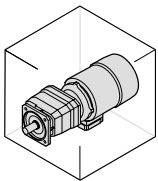

W = Default

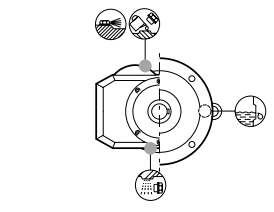
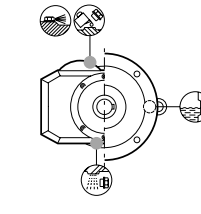
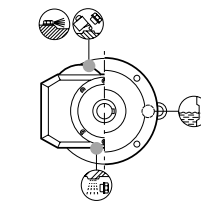
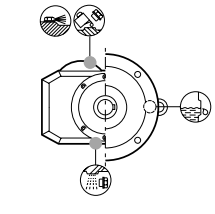
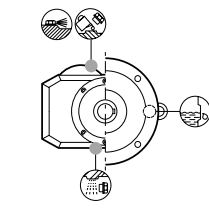

2x  
3x

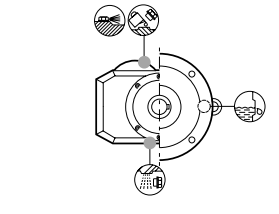

4x

B53

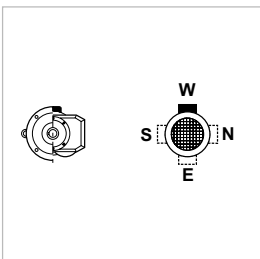
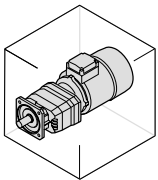

W = Default

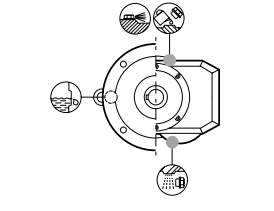
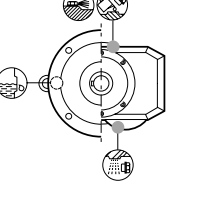
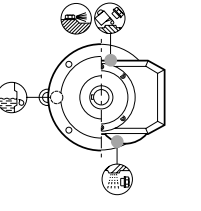
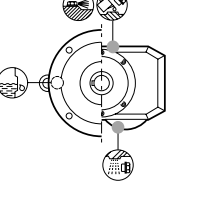
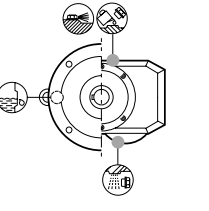

2x  
3x

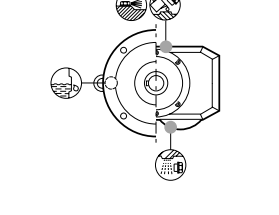

4x



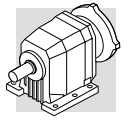

## C\_F

## C\_U

## C\_UF

(B12)

**\_HS**

**\_P (IEC)**

**\_S**

### B52

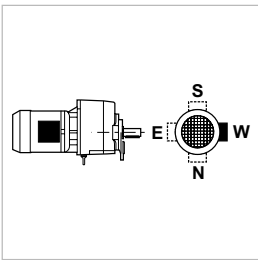
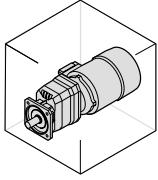

W = Default

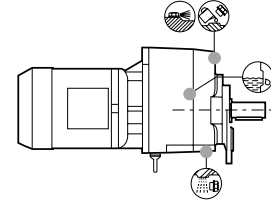
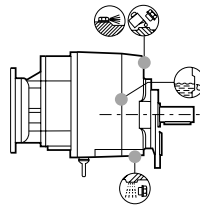
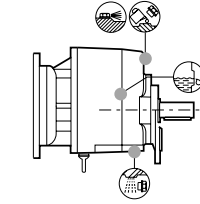
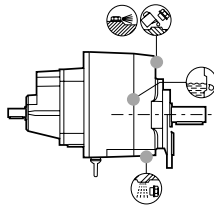
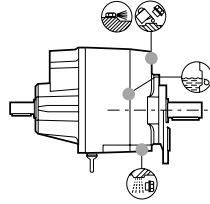

← 2x  
3x

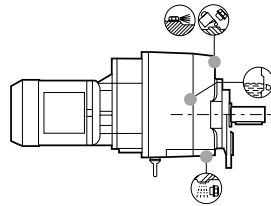

← 4x

### V1

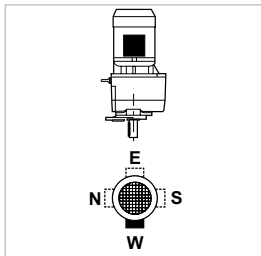
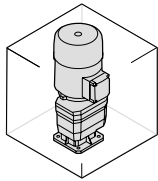

W = Default

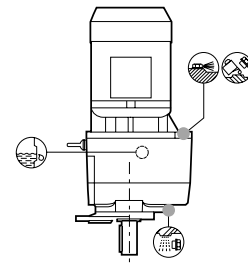
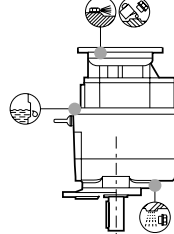
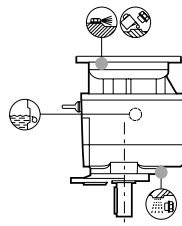
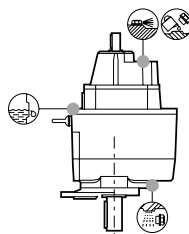
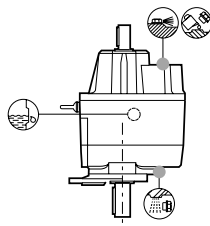

← 2x  
3x

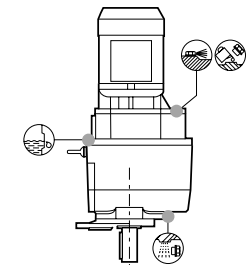

← 4x

### V3

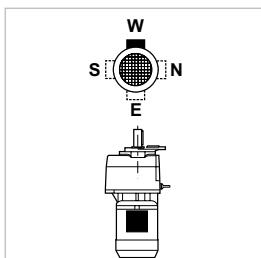
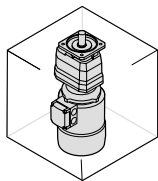

W = Default

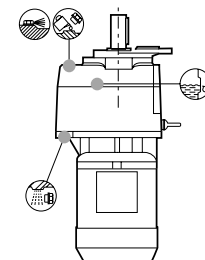
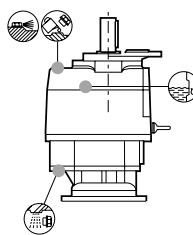
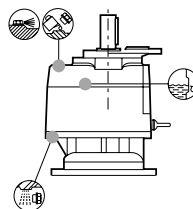
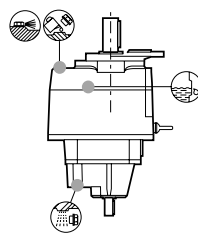
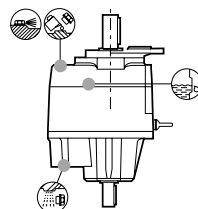

← 2x  
3x

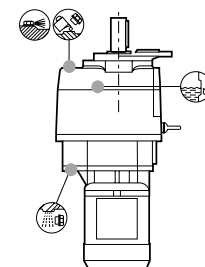

← 4x